

CHAPTER > 12

Thermodynamics

KEY NOTES

- **Thermodynamics** is the branch of physics that deals with the concepts of heat and temperature and the inter-conversion of heat into other forms of energy.

Thermal Equilibrium

- A thermodynamic system is said to be in thermal equilibrium, when macroscopic variables (like pressure, volume, temperature, mass, composition, etc.) that characterise the system do not change with time.
Terms that may help to describe thermal equilibrium are
- **Adiabatic wall** is an insulating wall (can be movable) separating the two systems that does not allow flow of energy (heat) from one system to another.
- **Diathermic wall** is a conducting wall separating of the two systems that allows energy flow (heat) from one system to another.

Internal Energy, Heat and Work

- **Internal energy** (U) includes only the (disordered) energy (i.e. sum of kinetic and potential energies) associated with the random motion of molecules of the system.
Its value depends only on the given state of the system, not on the path taken to arrive at that state.
- **Heat** is the energy transfer due to temperature difference between the systems and the surroundings.
- **Work** is the energy transfer brought about by means that do not involve such a temperature difference.
- Heat and work are two different modes of altering the state of a thermodynamic system that results in change in its internal energy.

Zeroth and First Law of Thermodynamics

- Zeroth law of thermodynamics states that, if two systems A and B are in thermal equilibrium with a third system C separately, then A and B will be in thermal equilibrium with each other.
- First law of thermodynamics is the extension of energy conservation for a thermodynamic process.
According to this law, $\Delta Q = \Delta U + \Delta W$, where ΔQ is the heat supplied to the system, ΔU is the increase in internal energy and ΔW is the work done by the system on the surroundings.

Specific Heat Capacity

- It is given as $s = \frac{S}{m} = \frac{1}{m} \frac{\Delta Q}{\Delta T}$.
where, $S = \frac{\Delta Q}{\Delta T}$ = heat capacity, ΔQ = heat supplied
and ΔT = change in temperature.

It depends on the nature of the substance and its temperature. Its SI unit is $\text{J kg}^{-1} \text{K}^{-1}$.

- **Molar specific heat capacity** is given as

$$C = \frac{S}{\mu} = \frac{1}{\mu} \frac{\Delta Q}{\Delta T}$$

where, μ is the number of moles of the substance, S is heat capacity and ΔT is change in temperature.

It is independent of the amount of substance but depends on the nature of the substance, its temperature and the conditions under which heat is supplied. Its SI unit is $\text{J mol}^{-1} \text{K}^{-1}$.

- For gases two types of molar specific heats are defined; molar specific heat capacity at constant volume (C_V) and molar specific heat capacity at constant pressure (C_p).
- For an ideal gas, $C_p - C_V = R$
where, R = universal gas constant.

- **One calorie** is defined to be the amount of heat required to raise the temperature of 1g of water from 14.5°C to 15.5°C.
- In SI units, specific heat capacity of water is $4186 \text{ J kg}^{-1} \text{ K}^{-1}$, i.e. $4.186 \text{ J g}^{-1} \text{ K}^{-1}$.
- **Mechanical equivalent of heat** is defined as the amount of work needed to produce 1 cal of heat.

Thermodynamic State Variables

- Every equilibrium state of a thermodynamic system is completely described by specific values of some macroscopic variables, also called **state variables**.
- The connection between the state variables is called the **equation of state**. e.g. For an ideal gas, the equation of state is ideal gas relation, i.e. $pV = \mu RT$.
- The thermodynamic state variables are of two kinds extensive and intensive.
 - (i) **Extensive variables** indicate the size of the system. e.g.. Internal energy U , volume V , total mass M , heat energy ΔQ , etc.
 - (ii) **Intensive variables** do not indicate the size of the system. e.g. Pressure p , temperature T and density ρ .

Thermodynamic Processes

- A **quasi-static process** is an idealised process in which at every stage, the system is in equilibrium state. During this process, the system changes its variables, (p, T, V) , so slowly that it remains in (thermal and mechanical) equilibrium with its surroundings throughout.
- **Isothermal process** is a process in which temperature of the system is kept constant during the change in state. Following are the important points related to this process
 - (i) Process equation is $pV = \text{constant}$.
 - (ii) Work done is $W = \mu RT \ln\left(\frac{V_2}{V_1}\right) = \mu RT \ln\left(\frac{p_1}{p_2}\right)$
 - (iii) Since, for an ideal gas, U depends only on T . Thus, there is no change in the internal energy ($\Delta U = 0$) of an ideal gas in an isothermal process. So, first law of thermodynamics, then implies $\Delta Q = \Delta W$.
 - (iv) The pressure-volume curve for a fixed temperature is called an **isotherm**.
 - (v) p - V curve is a rectangular hyperbola.
- **Adiabatic process** is a process in which the system is insulated from the surroundings and the heat absorbed or released is zero. Following are the important points related to this process
 - (i) Process equation is $pV^\gamma = \text{constant}$.

where, $\gamma = \frac{C_p}{C_v}$

Above equation can be written in other ways as $TV^{\gamma-1} = \text{constant}$ or $p^{1-\gamma}T^\gamma = \text{constant}$.

(ii) Work done is $W = \frac{\mu R(T_1 - T_2)}{\gamma - 1} = \frac{p_1 V_1 - p_2 V_2}{\gamma - 1}$

(iii) Slope of p - V curve in an adiabatic process is γ times the slope of p - V curve in isothermal process.

- **Isochoric process** is a process in which volume is kept constant.

Following are the important points related to this process

(i) Process equation is $\frac{p}{T} = \text{constant}$.

(ii) Work done is $W = 0$.

(iii) p - V curve is a straight line parallel to pressure axis.

- **Isobaric process** is a process in which pressure is kept constant.

Following are the important points related to this process

(i) Process equation is $\frac{V}{T} = \text{constant}$.

(ii) Work done is $W = p(V_2 - V_1) = \mu R(T_2 - T_1)$.

(iii) p - V curve is a straight line parallel to volume axis.

- **Cyclic process** is a process in which the system returns to its initial state.

Following are the important points related to this process

(i) As initial and final states are the same, so $\Delta U = 0$ for a cyclic process.

(ii) Total heat absorbed equals the work done by the system.

(iii) Work done during the cyclic process can be computed from area enclosed by the cycle on p - V curve.

Note If the cycle is clockwise, work is done by the system is positive and if the cycle is anti-clockwise, work is done on the system is negative.

- **Indicator diagram or p - V curves** for different processes are as follows

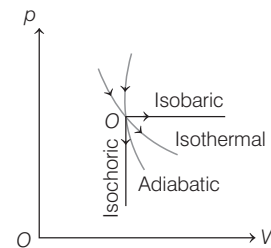

We can compare the work done by each of these processes by computing area under the p - V curve.

Heat Engine

It is a device by which a system is made to undergo a cyclic process that results in conversion of heat into work continuously.

Schematic representation of a heat engine is as follows

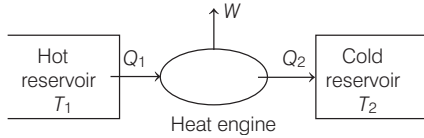

$$\text{Efficiency, } \eta = \frac{W}{Q_1} = \frac{Q_1 - Q_2}{Q_1} = 1 - \frac{Q_2}{Q_1}$$

where, W = work done on the environment in a cycle,

Q_1 = heat absorbed from a source at T_1

and Q_2 = heat rejected to the sink at T_2 .

Note For an ideal engine $\eta = 1$, which is never possible.

Refrigerator or Heat Pump

A refrigerator is basically a reverse heat engine.

Schematic representation of a refrigerator is as follows

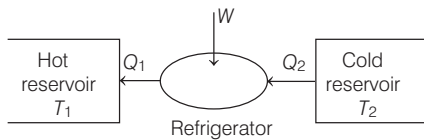

Coefficient of performance of refrigerator,

$$\alpha = \frac{\text{Heat extracted}}{\text{Work done}} = \frac{Q_2}{W} = \frac{Q_2}{Q_1 - Q_2}$$

In the case of heat pump, $\alpha = \frac{Q_1}{W}$

Note α can never be infinite.

Second Law of Thermodynamics

It gives a fundamental limitation to the efficiency of a heat engine and the coefficient of performance of refrigerator.

It can be stated as

Kelvin-Planck statement No process is possible whose sole result is the absorption of heat from a reservoir and the complete conversion of the heat into work.

Clausius statement No process is possible whose sole result is the transfer of heat from a colder body to hotter body.

Reversible and Irreversible Processes

- A process which can be reversed in such a way that the system and its surrounding return exactly to their initial states with no other changes in the universe is known as **reversible process**.
- Any process which is not reversible exactly is an **irreversible process**.

- Heat engine based on idealised reversible processes achieves the highest efficiency possible. All other engines involving irreversibility in any way have lower than this limiting efficiency.

Carnot Engine

- It is a reversible heat engine operating between two temperatures. A Carnot cycle is as shown in the figure below

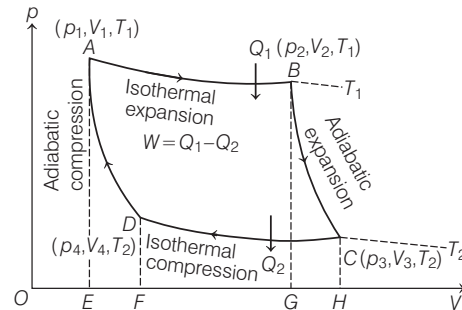

From the given curve, we get

$$W_{A \rightarrow B} = W_1 = Q_1 = \mu R T_1 \ln \left(\frac{V_2}{V_1} \right)$$

$$W_{B \rightarrow C} = W_2 = \frac{\mu R (T_1 - T_2)}{\gamma - 1}$$

$$W_{C \rightarrow D} = W_3 = Q_2 = \mu R T_2 \ln \left(\frac{V_3}{V_4} \right)$$

$$W_{D \rightarrow A} = W_4 = \mu R \left(\frac{T_1 - T_2}{\gamma - 1} \right)$$

Net work done during the complete cycle,

$$\begin{aligned} W &= W_1 + W_2 + (-W_3) + (-W_4) \\ &= W_1 - W_3 = \text{Area } ABCD \quad (\text{As, } W_2 = W_4) \\ &= \mu R T_1 \ln \left(\frac{V_2}{V_1} \right) - \mu R T_2 \ln \left(\frac{V_3}{V_4} \right) \end{aligned}$$

\therefore Efficiency of Carnot cycle,

$$\eta = \frac{W}{Q_1} = \frac{W_1 - W_3}{W_1} = \frac{Q_1 - Q_2}{Q_1} = 1 - \frac{Q_2}{Q_1} = 1 - \frac{T_2}{T_1}$$

\therefore For a Carnot cycle, $\frac{Q_1}{Q_2} = \frac{T_1}{T_2}$

- **Carnot's theorem** states that
 - (i) working between the temperatures T_1 and T_2 of a hot and cold reservoir respectively, no engine can have efficiency more than that of the Carnot engine.
 - (ii) the efficiency of the Carnot engine is independent of the nature of the working substance.

Mastering NCERT

MULTIPLE CHOICE QUESTIONS

TOPIC 1 ~ Thermal Equilibrium and Zeroth Law of Thermodynamics

- 1** According to initial theory, the heat was considered as fluid called 'caloric'. This caloric
- (a) flows from hotter to colder body
 - (b) flows from colder to hotter body
 - (c) could flow in either direction, depending on height of the bodies
 - (d) None of the above
- 2** Choose the correct options regarding thermodynamics.
- (a) Its laws were established before molecular picture of matter was established.
 - (b) It deals with conversion of heat into other forms of energy.
 - (c) It deals with macroscopic variables like volume, temperature, mass, etc.
 - (d) All of the above
- 3** In the figure below, two systems A and B are separated by an insulating fixed wall (adiabatic wall) and also insulated from surroundings by insulated wall.

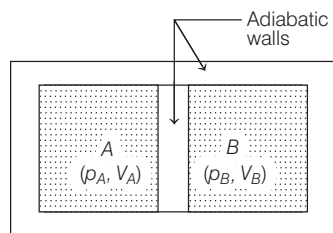

Choose the correct option regarding above information.

- (a) The pressures of A and B will change with time.
 - (b) The temperatures of A and B will change with time.
 - (c) The thermodynamic states of A and B will not change with time.
 - (d) None of the above
- 4** If two systems are in thermal equilibrium with each other, it means their
- (a) masses are equal, temperatures may be unequal
 - (b) temperatures are equal
 - (c) masses and temperatures both are equal
 - (d) None of the above
- 5** If a system is in thermodynamic equilibrium with its surroundings, it means
- (a) temperature of system and surroundings must be same
 - (b) pressure and volume of system and surroundings must be same
 - (c) pressure, volume and temperature of system and surroundings may be different
 - (d) None of the above
- 6** Choose the correct option from the following.
- (a) Zeroth law gives the concept of temperature.
 - (b) Temperature measures the 'hotness' of the body.
 - (c) Heat flows from the body at higher temperature to the one a lower temperature, until thermal equilibrium is attained.
 - (d) All of the above
- 7** According to Zeroth law, which physical quantity must have same value for the two systems to be in thermal equilibrium?
- (a) Pressure
 - (b) Temperature
 - (c) Volume
 - (d) Composition
- 8** According to Zeroth law of thermodynamics, if two systems A and B are separately in equilibrium with C , then
- (a) $T_A = T_B$
 - (b) $T_A > T_C, T_B > T_C$ and $T_A = T_B$
 - (c) $T_A = T_C$ and $T_A \neq T_B$
 - (d) $T_A < T_C, T_B < T_C$ and $T_A = T_B$

TOPIC 2~ Heat, Internal Energy and Work : First Law of Thermodynamics

- 9 Internal energy U of a gas depends on the
- kinetic energy of the system
 - molecular kinetic and potential energies
 - disordered energy associated with the random motion of the molecules
 - Both (b) and (c)

- 10 The internal energy of a gas contained in a movable box moving with a constant speed v

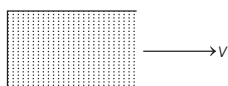

- depends on v
- does not depend on v
- depends only on molecular energies
- Both (b) and (c)

- 11 Consider a system to be a certain mass of gas contained in a cylinder with movable piston as shown in the figure.

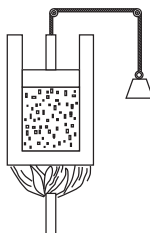

- The state of the gas and hence its internal energy can be changed by
- putting the cylinder in contact with the body at a higher temperature than gas
 - pushing the piston down
 - Either (a) or (b)
 - Neither (a) nor (b)

- 12 The internal energy of a system could be changed
- by extracting heat from the system
 - by doing work done on the system
 - if system do some work on the surroundings
 - All of the above

- 13 Amongst the following variables, state variable is (are)
- heat
 - work
 - internal energy
 - All of these

- 14 An ideal monoatomic gas is taken from A to B by the following three ways p , q , r as shown in the given p - V curve.

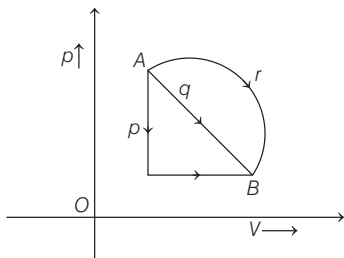

Then, amongst which of these ways, the internal energy would be same?

- p and r
- q and r
- p and q
- For all the ways internal energy is same

- 15 If the system is a gas in a cylinder with a movable piston as shown in the figure alongside, then

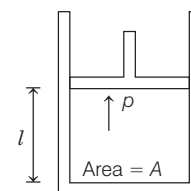

- $\Delta W = pV$
- $\Delta W = \Delta pV$
- $\Delta W = p\Delta V$
- $\Delta W = p\Delta V + V\Delta p$

- 16 A system is provided with 200 cal of heat and the work done by the system on the surroundings is 40 J. Then, its internal energy

- increases by 600 J
- decreases by 800 J
- increases by 800 J
- decreases by 50 J

- 17 1g of water of volume 1 cm^3 at 100°C is converted into steam at same temperature under normal atmospheric pressure ($\approx 1 \times 10^5 \text{ Pa}$). The volume of steam formed equals 1671 cm^3 . If the specific latent heat of vaporisation of water is 2256 J/g , the change in internal energy is

NEET (Odisha) 2019

- 2423 J
- 2089 J
- 167 J
- 2256 J

- 18 A sample of 0.1 g of water at 100°C and normal pressure ($1.013 \times 10^5 \text{ Nm}^{-2}$) requires 54 cal of heat energy to convert to steam at 100°C . If the volume of the steam produced is 167.1 cc, the change in internal energy of the sample, is

NEET 2018

- 42.2 J
- 208.7 J
- 104.3 J
- 84.5 J

- 19 Heat capacity of a substance can be increased

- by decreasing the mass of the substance
- by increasing the rise in temperature
- by increasing the mass of the substance
- Both (b) and (c)

- 20 Molar specific heat capacity C of a substance having μ moles

- can be represented by $\frac{1}{\mu} \frac{\Delta Q}{\Delta T}$
- is different for different amount of substance
- can be varied depending upon change in the temperature risen
- Both (a) and (c)

- 21** From the following graphs given in the options, variation of specific heat capacity of water with temperature is correctly represented in

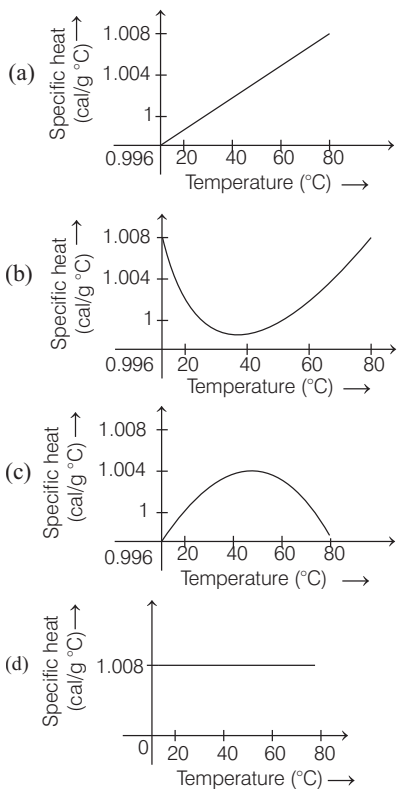

- 22** Mechanical equivalent of heat is equal to the amount of
 (a) work done to produce 1 cal heat
 (b) a conversion factor between calorie and joule
 (c) Both (a) and (b)
 (d) Neither (a) nor (b)
- 23** An ideal gas having molar specific heat capacity at constant volume is $\frac{3}{2}R$, the molar specific heat capacity at constant pressure is
 (a) $\frac{1}{2}R$ (b) $\frac{5}{2}R$
 (c) $\frac{7}{2}R$ (d) $\frac{9}{2}R$
- 24** For an ideal gas, the molar specific heat capacities at constant pressure and volume are C_p and C_v respectively. Choose the correct option.
 (a) $C_v = \left(\frac{\Delta U}{\Delta T}\right)_v$ (b) $C_p = \left(\frac{\Delta U}{\Delta T}\right)_p + p\left(\frac{\Delta V}{\Delta T}\right)_p$
 (c) $p\left(\frac{\Delta V}{\Delta T}\right)_p = R$ (d) All of these
- 25** 310 J of heat is required to raise the temperature of 2 mol of an ideal gas at constant pressure from 25°C to 35°C. The amount of heat required to raise the temperature of the gas through the same range at constant volume is
 (a) 384 J (b) 144 J
 (c) 276 J (d) 452 J

TOPIC 3~ Thermodynamic State Variables and Processes

- 26** Consider a situation in which a mixture of petrol vapour and air when ignited by a spark. Then, the gases undergo explosion
 (a) initially have non-uniform temperature and pressure
 (b) cannot be described by state variables initially
 (c) may eventually attain an equilibrium state with its surroundings after a certain time
 (d) All of the above
- 27** A system in equilibrium is divided into two equal parts. The systems before and after the division, with respective state variables are as shown below.

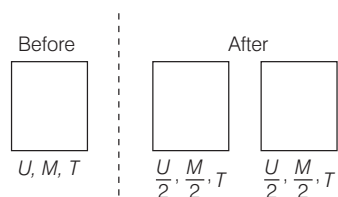

- Then, from the above, we can say that
 (a) U is an extensive state variable, whereas M and T are intensive state variables
 (b) T is an extensive state variable, whereas U and M are intensive state variables
 (c) U and M are extensive state variables, whereas T is intensive state variable
 (d) U , M and T all are extensive state variables
- 28** A quasi-static process means
 (a) a nearly static process
 (b) that the change in p , V and T of the system occur in such a ways that it remains in equilibrium at every instant with its surroundings
 (c) Both (a) and (b)
 (d) Neither (a) nor (b)

- 29** In which of the following processes, heat is neither absorbed nor released by a system?

- NEET (National) 2019**
- (a) Adiabatic (b) Isobaric
 (c) Isochoric (d) Isothermal

- 30** For the given isothermal process $A \rightarrow B$ of an ideal gas, area under the graph is 20 J, then

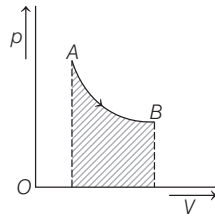

- (a) $\Delta Q = 0$
 (b) $\Delta Q = +20 \text{ J}$
 (c) $\Delta U = -20 \text{ J}$
 (d) None of the above

- 31** Identify the graph (s) which correctly represents an isotherm at temperatures T_1 and T_2 ($T_2 > T_1$).

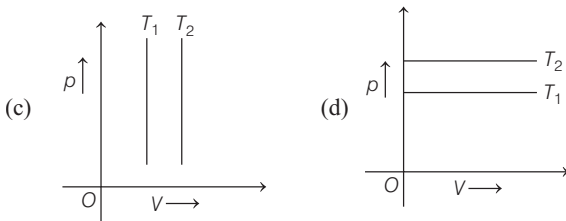
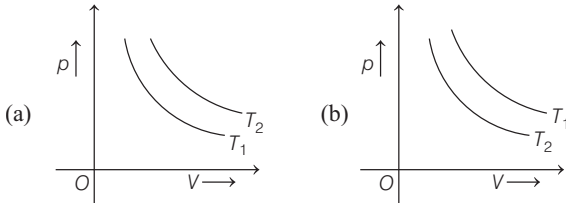

- 32** Among given curves, which one could represent isothermal process?

- (a) Curve A
 (b) Curve B
 (c) Curve C
 (d) None of the curves could represent isothermal process

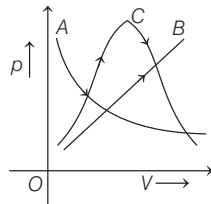

- 33** For an isothermal expansion or compression, (where ΔW_1 and ΔW_2 are the net work for expansion and compression, respectively)

- (a) $\Delta W_1 = -ve$; $\Delta W_2 = +ve$
 (b) $\Delta W_1 = \Delta W_2$; $\Delta W_2 = -ve$
 (c) $\Delta W_1 = +ve$; $\Delta W_2 = -ve$
 (d) $\Delta W_1 = \Delta W_2$, at every stage

- 34** 10 mol of an ideal gas at constant temperature 500 K is compressed from 50 L to 5 L. Work done in the process is (given, $R = 8.31 \text{ J mol}^{-1} \text{ K}^{-1}$)

- (a) $-1.2 \times 10^4 \text{ J}$ (b) $-2.4 \times 10^4 \text{ J}$
 (c) $-4.8 \times 10^4 \text{ J}$ (d) $-9.6 \times 10^4 \text{ J}$

- 35** If work is done on the system in an adiabatic process,

- (a) $T_f < T_i$
 (b) $T_f = T_i$
 (c) $T_f > T_i$
 (d) information is insufficient

- 36** The temperature of an ideal gas increases to 2 times when compressed adiabatically to half the volume. Its equation of state can be written as

- (a) $pV^{3/2} = \text{constant}$ (b) $pV^{4/3} = \text{constant}$
 (c) $pV^{1/2} = \text{constant}$ (d) $pV^2 = \text{constant}$

- 37** Amongst the following relations which is true in the case of an adiabatic process, where $\gamma = C_p/C_v$.

- (a) $p^{1-\gamma} T^\gamma = \text{constant}$ (b) $p^\gamma T^{1-\gamma} = \text{constant}$
 (c) $pT^\gamma = \text{constant}$ (d) $p^\gamma T = \text{constant}$

- 38** In an adiabatic process, when pressure is increased by $\frac{2}{3}\%$. If $\frac{C_p}{C_v} = \frac{3}{2}$, then the volume decreases by about

- (a) $\frac{4}{9}\%$ (b) $\frac{2}{3}\%$ (c) 4% (d) $\frac{9}{4}\%$

- 39** A gas consisting of rigid diatomic molecules was initially under standard condition, then gas was compressed adiabatically to one-fifth of its initial volume. What will be the mean kinetic energy of a rotating molecule in the final state? **AIIMS 2018**

[Take, γ for diatomic gas = $\frac{7}{5}$]

- (a) 1.44 J (b) 4.55 J
 (c) $787.98 \times 10^{-23} \text{ J}$ (d) $757.3 \times 10^{-23} \text{ J}$

- 40** A gas is taken from V_i to V_f by two processes, one is isothermal and other is adiabatic.

Choose the correct option regarding the p - V diagram for two processes.

- (a) $(\text{Slope})_{\text{isothermal}} = (\text{Slope})_{\text{adiabatic}}$
 (b) $(\text{Slope})_{\text{isothermal}} > (\text{Slope})_{\text{adiabatic}}$
 (c) $(\text{Slope})_{\text{isothermal}} < (\text{Slope})_{\text{adiabatic}}$
 (d) Information is insufficient

- 41** A gas is compressed isothermally to half of its initial volume. The same gas is compressed separately through an adiabatic process until its volume is again reduced to half. Then, **NEET 2016**

- (a) compressing the gas through adiabatic process will require more work to be done
 (b) compressing the gas isothermally or adiabatically will require the same amount of work
 (c) the case (whether compression through isothermal or through adiabatic process) which of requires more work will depend upon the atomicity of the gas
 (d) compressing the gas isothermally will require more work to be done

- 42** The work done in which of the following process is zero?

- (a) Isothermal process
 (b) Adiabatic process
 (c) Isochoric process
 (d) Isobaric process

- 43** A container having 1 mol of a gas at a temperature 27°C has movable piston which maintains constant pressure of 1 atm in container. The gas is compressed until temperature becomes 127°C . The work done is (C_p for gas is $7.03 \text{ cal/mol}\cdot\text{K}$)
- (a) 703 J (b) 831 J
(c) 121 J (d) 2035 J

- 44** In an isobaric process, the work done by a di-atomic gas is 10 J, the heat given to the gas will be [C_p for diatomic gas $= \frac{7}{2} R$] **JEE Main 2019, AIIMS 2019**
- (a) 35 J (b) 30 J
(c) 45 J (d) 60 J

- 45** 1 mol of an ideal gas goes from an initial state A to final state B via two processes. It first undergoes isothermal expansion from volume V to $3V$ and then its volume is reduced from $3V$ to V at constant pressure. The correct p - V diagram representing the two processes is **CBSE AIPMT 2012**

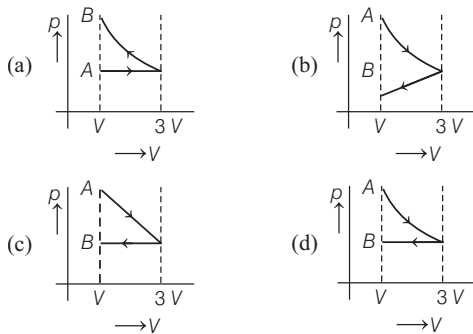

- 46** A thermodynamic system undergoes cyclic process $ABCD$ as shown in figure. The work done by the system in the cycle is **CBSE AIPMT 2014**
- (a) $\frac{p_0 V_0}{2}$ (b) zero
(c) $p_0 V_0$ (d) $2p_0 V_0$

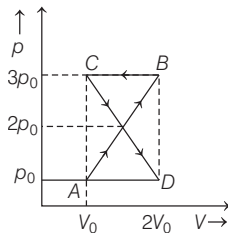

- 47** Figure below shows two paths that may be taken by a gas to go from a state A to a state C .

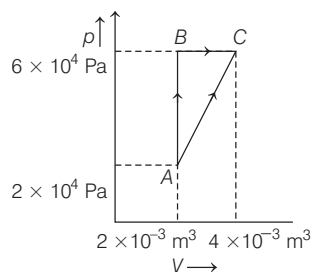

- In process AB , 400 J of heat is added to the system and in process BC , 100 J of heat is added to the system. The heat absorbed by the system in the process AC will be **CBSE AIPMT 2015**
- (a) 300 J (b) 380 J (c) 500 J (d) 460 J

- 48** A sample of an ideal gas is taken through the cyclic process $abca$ as shown in the figure. The change in the internal energy of the gas along the path ca is -180 J . The gas absorbs 250 J of heat along the path ab and 60 J along the path bc . The work done by the gas along the path abc is **JEE Main 2019**

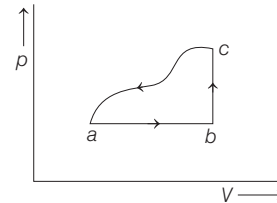

- (a) 120 J (b) 130 J (c) 100 J (d) 140 J

- 49** The efficiency of an ideal gas with adiabatic exponent γ for the shown cyclic process would be **JIPMER 2018**

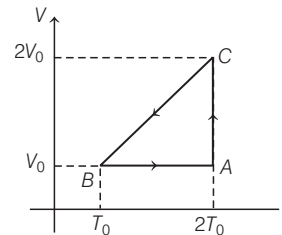

- (a) $\frac{(2\ln 2 - 1)}{\gamma / (\gamma - 1)}$ (b) $\frac{(1 - \ln 2)}{\gamma / (\gamma - 1)}$
(c) $\frac{(2\ln 2 + 1)}{\gamma / (\gamma - 1)}$ (d) $\frac{(2\ln 2 - 1)}{\gamma / (\gamma + 1)}$

- 50** Following figure shows two processes A and B for a gas. If ΔQ_A and ΔQ_B are the amount of heat absorbed by the system in two cases, and ΔU_A and ΔU_B are changes in internal energies respectively, then **JEE Main 2019**

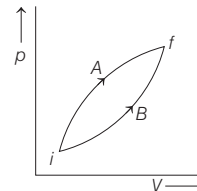

- (a) $\Delta Q_A > \Delta Q_B$, $\Delta U_A > \Delta U_B$
(b) $\Delta Q_A < \Delta Q_B$, $\Delta U_A < \Delta U_B$
(c) $\Delta Q_A > \Delta Q_B$, $\Delta U_A = \Delta U_B$
(d) $\Delta Q_A = \Delta Q_B$, $\Delta U_A = \Delta U_B$

TOPIC 4 ~ Heat Engines, Refrigerators and Heat Pumps

- 51 A device by which a system is made to undergo cyclic process that results in conversion of heat into work is
 (a) rotating blades
 (b) heat engine
 (c) a container with explosive chemicals
 (d) None of the above
- 52 Choose the correct option regarding the schematic representation of heat engine given below

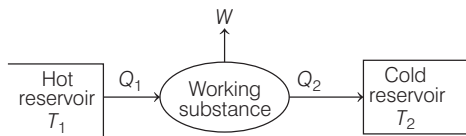

- (a) Working substance takes Q_1 heat from hot reservoir
 (b) Working substance does work $W = Q_1 - Q_2$ on the environment
 (c) Efficiency of the engine decreases with the increase in Q_1
 (d) All of the above

- 53 Consider a heat engine as shown in figure. Q_1 and Q_2 are heat added to T_1 and heat taken from T_2 in one cycle of engine. W is the mechanical work done on the engine.

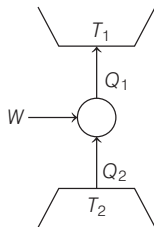

If $W > 0$, then possibilities are

- (a) $Q_1 > Q_2 > 0$ (b) $Q_2 < Q_1 < 0$
 (c) $Q_1 < 0, Q_2 > 0$ (d) Both (a) and (b)
- 54 If the efficiency of an engine is 50% and its work output is 500 J, then find the value of work input.

JIPMER 2018

- (a) 1000 J (b) 500 J (c) 100 J (d) 250 J

- 55 The efficiency of an ideal heat engine working between the freezing point and boiling point of water, is
 (a) 6.25% (b) 20% (c) 26.8% (d) 12.5%
 NEET 2018

- 56 The efficiency of a heat engine is $1/6$. When the temperature of sink is decreased by 62°C , its efficiency doubled. Then, what is the temperature of source?
 (a) 470°C (b) 372°C (c) 542°C (d) 1042°C
 JIPMER 2018

- 57 The device which is used in order to pump heat inside a room in a building when the outside environment is cold is

- (a) refrigerator (b) heat pump
 (c) heat engine (d) Either (a) or (c)

- 58 A refrigerator works between 4°C and 30°C . It is required to remove 600 cal of heat every second in order to keep the temperature of the refrigerated space constant. The power required is
 (Take, $1 \text{ cal} = 4.2 \text{ J}$)

NEET 2016

- (a) 23.65 W (b) 236.5 W (c) 2365 W (d) 2.365 W

- 59 An ideal refrigerator has a freezer at a temperature of -13°C . The coefficient of performance of the engine is 5. The temperature of the air (to which heat is rejected) will be

- (a) 325°C (b) 325°K (c) 39°C (d) 320°C

- 60 The temperature inside a refrigerator is $t_2^\circ\text{C}$ and the room temperature is $t_1^\circ\text{C}$. The amount of heat delivered to the room for each joule of electrical energy consumed ideally will be

NEET 2016

- (a) $\frac{t_1 + t_2}{t_1 + 273}$ (b) $\frac{t_1}{t_1 - t_2}$ (c) $\frac{t_1 + 273}{t_1 - t_2}$ (d) $\frac{t_2 + 273}{t_1 - t_2}$

TOPIC 5 ~ Second Law of Thermodynamics and Carnot Engine

- 61 According to second law of thermodynamics,
 (a) a heat engine cannot have efficiency equal to 1
 (b) a refrigerator (or heat pump) could have infinite value of coefficient of performance
 (c) a heat engine can fully convert heat into work
 (d) None of the above
- 62 According to Carnot, which type of engine working between two temperatures T_1 and T_2 have maximum efficiency?

- (a) Reversible engine
 (b) Irreversible engine
 (c) External combustion engine
 (d) Diesel engine

- 63 For Carnot engine, which process should be chosen to take the working substance from T_1 to T_2 or vice-versa?

- (a) Isochoric (b) Isothermal
 (c) Adiabatic (d) Isobaric

- 64 Given below figure shows a Carnot cycle, where a Carnot engine is operating between two temperatures T_1 and T_2 . Here, working substance is an ideal gas.

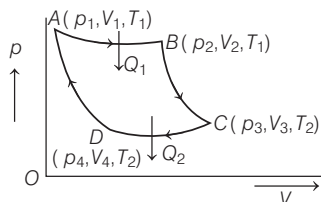

Total work done by the gas in one complete cycle,

- (a) $\mu RT_2 \log \frac{V_2}{V_1} - \mu RT_1 \log \frac{V_3}{V_4}$
 (b) $\mu RT_1 \log \frac{V_2}{V_1} - \mu RT_2 \log \frac{V_3}{V_4}$
 (c) $\mu RT_1 \log \frac{V_2}{V_1} + \mu RT_2 \log \frac{V_3}{V_4}$
 (d) zero
- 65 Two ideal Carnot engines operate in cascade (all heat given up by one engine is used by the other engine to produce work) between temperatures T_1 and T_2 . The temperature of the hot reservoir of the first engine is T_1 and the temperature of the cold reservoir of the second engine is T_2 . T is temperature of the sink of

first engine which is also the source for the second engine. How is T related to T_1 and T_2 , if both the engines perform equal amount of work? **JEE Main 2020**

- (a) $T = 0$ (b) $T = \frac{2T_1T_2}{T_1 + T_2}$
 (c) $T = \sqrt{T_1 T_2}$ (d) $T = \frac{T_1 + T_2}{2}$
- 66 A Carnot engine absorbs 6×10^5 cal at 227°C . The work done per cycle by the engine, if its sink is maintained at 127°C is **JIPMER 2018**
 (a) 15×10^8 J (b) 15×10^4 J (c) 5×10^5 J (d) 2×10^4 J
- 67 A Carnot engine has an efficiency of $1/6$. When the temperature of the sink is reduced by 62°C , its efficiency is doubled. The temperatures of the source and the sink are respectively, **JEE Main 2019**
 (a) 62°C , 124°C (b) 99°C , 37°C
 (c) 124°C , 62°C (d) 37°C , 99°C
- 68 A Carnot engine having an efficiency of $\frac{1}{10}$ as heat engine, is used as a refrigerator. If the work done on the system is 10J, the amount of energy absorbed from the reservoir at lower temperature is **NEET 2017, CBSE AIPMT 2015, JEE Main 2020**
 (a) 1 J (b) 90 J (c) 99 J (d) 100 J

SPECIAL TYPES QUESTIONS

I. Assertion and Reason

■ **Direction** (Q. Nos. 69-80) In the following questions, a statement of Assertion is followed by a corresponding statement of Reason. Of the following statements, choose the correct one.

- (a) Both Assertion and Reason are correct and Reason is the correct explanation of Assertion.
 (b) Both Assertion and Reason are correct but Reason is not the correct explanation of Assertion.
 (c) Assertion is correct but Reason is incorrect.
 (d) Assertion is incorrect but Reason is correct.
- 69 **Assertion** Specific heat capacity and molar specific heat capacity both have same units.
Reason Specific heat capacity and molar specific heat capacity both do not depend on mass.
- 70 **Assertion** In equation $\Delta Q = \Delta U + p\Delta V$, quantities on the both sides are intensive.
Reason The product of an intensive variable like p and an extensive quantity ΔV is extensive.

71 **Assertion** In isothermal process, whole of the heat energy supplied to the body is converted into internal energy.

Reason According to the first law of thermodynamics, $\Delta Q = \Delta U + \Delta W$. **AIIMS 2018**

72 **Assertion** In adiabatic process, work is independent of the path.

Reason In adiabatic process, work done is equal to negative of change in internal energy. **AIIMS 2019**

73 **Assertion** Heat absorbed by the gas during an isochoric process goes entirely to change its internal energy and its temperature.

Reason In an isochoric process, volume is constant.

74 **Assertion** In cyclic process, $\Delta U = 0$.

Reason Cyclic process means a reversible process.

75 **Assertion** Coefficient of performance of a refrigerator cannot be infinite.

Reason Refrigerator cannot work without some external work done on the system.

76 Assertion First law of thermodynamics is based on energy conservation.

Reason Second law of thermodynamics put limitations on first law.

77 Assertion Rotating blade in a liquid stops after a certain time is a irreversible process.

Reason Irreversibility arises as the system attains a non-equilibrium state.

78 Assertion Reversible Carnot engine with one particular substance cannot be more efficient than the one using another substance.

Reason Efficiency of Carnot engine $= T_2/T_1$.

79 Assertion The efficiency of Carnot engine can be 100%.

Reason Carnot engine is reversible engine.

80 Assertion Consider I as an irreversible heat engine and R as a reversible heat engine working between the same source and sink at temperatures T_1 and T_2 , respectively. If they are coupled such that I acts as a heat engine and R as a refrigerator ($T_1 > T_2$), then $\eta_R < \eta_I$.

Reason According to second law of thermodynamics, efficiency of reversible Carnot engine is maximum.

II. Statement Based Questions

- 81** I. Benjamin Thomson experiment demonstrated conversion of energy from one form to another (from work to heat).
 II. Temperature is related to the motion of particles as a whole, not to energy of the internal (disordered) motion of particles.
 III. Whether or not a system is in a state of equilibrium, it is independent of the surroundings and nature of the wall that separates the system from the surroundings.

Choose the correct statement.

- (a) Only I (b) Both II and III
 (c) Only II (d) I, II and III

82 Study the following statements.

- I. One calorie is equal to the amount of heat required to raise the temperature of 1 g of water by 1°C , i.e. from 14.5°C to 15.5°C .
 II. In SI units, specific heat capacity of water is $2148 \text{ J kg}^{-1} \text{ K}^{-1}$.

Choose the correct statement.

- (a) Only I (b) Only II
 (c) Both I and II (d) Neither I nor II

83 A gas is enclosed in a box with a partition as shown in the Fig. (a).

If this partition in the box is suddenly removed [as shown in Fig. (b)] leading to free expansion of the gas, then

- I. it is not an equilibrium state.
 II. state variables can be used to describe the situation.

Which amongst the given statements is (are) correct?

- (a) Only I (b) Only II
 (c) Both I and II (d) Neither I nor II

84 Study the following statements.

- I. ΔQ and ΔW are path independent.
 II. $\Delta Q - \Delta W$ is path dependent.
 III. When $\Delta U = 0$, then heat supplied to the system is used up entirely by the system in doing work on the environment.

Choose the correct statement.

- (a) Only I (b) Only II
 (c) Only III (d) Both I and II

85 For an isothermal process,

- I. pressure of a given mass of a gas varies inversely as its volume.
 II. during expansion of gas, work is done by the gas on environment.
 III. during compression heat is released.

Choose the correct statement.

- (a) Only II (b) Both I and II
 (c) Both I and III (d) I, II and III

86 In a heat engine,

- I. work done (W) by the system in a cycle is transferred to the environment *via* some arrangement, e.g. the working substance in a cylinder with a moving piston transfers mechanical energy to the wheels of a vehicle *via* a shaft.
 II. working substance can be a mixture of fuel, vapour and air in gasoline.

Choose the incorrect statement (s).

- (a) Only I (b) Only II
 (c) Both I and II (d) Neither I nor II

87 For a given heat engine,

- I. efficiency can be 1.
 II. mechanism of conversion of heat into work can be done by heating the system (say a gas or a mixture of gases) by an external furnace, as in a steam engine.

Choose the incorrect statement.

- (a) Only I (b) Only II
 (c) Neither I nor II (d) Both I and II

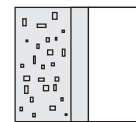

(a)

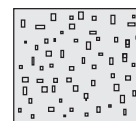

(b)

88 Study the following statements regarding second law of thermodynamics.

- I. Kelvin and Planck's statements deny the possibility of a perfect refrigerator or heat pump.
- II. Clausius statement denies the possibility of a perfect heat engine.

Choose the correct statement.

- (a) Only I (b) Only II
(c) Both I and II (d) Neither I nor II

89 A process is reversible, if

- I. it is quasi-static
- II. there are no dissipative effects.

Choose the correct statement (s).

- (a) Only I (b) Only II
(c) Both I and II (d) Neither I nor II

90 Following are statement of few processes taking place in nature.

- I. Free expansion of a gas.
- II. The combustion reaction of a mixture of petrol and air ignited by a spark.
- III. The leaking of a gas from the kitchen cylinder.
- IV. The transfer of heat from one heated part of a liquid to the other colder part.

Which amongst these processes are irreversible in nature?

- (a) Both I and II (b) III and IV
(c) II, III and IV (d) I, II, III and IV

91 Study the following statements regarding the steps a working substance of a refrigerator goes through,

- I. Sudden expansion of the gas from high to low pressure which cools it and converts it into vapour-liquid mixture.
- II. Absorption by the cold fluid of heat from the region to be cooled, converting it into vapour.
- III. heating up of the vapour due to external work done on the system.
- IV. absorption of heat by the vapour from the surroundings.

Choose the correct statement.

- (a) Only I (b) Both II and III
(c) Both III and IV (d) I, II and III

92 The two gases are separated by a fixed diathermic wall with initial states as (p_A, V_A) and (p_B, V_B) .

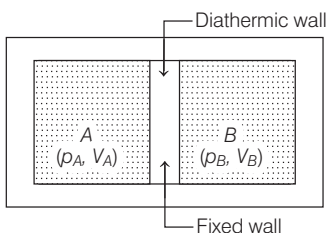

Choose the correct statement.

- (a) The thermodynamic states of A and B will not change with time.
- (b) There will be a flow of energy between the two systems until the equilibrium is attained.
- (c) The states of the two systems will change until the equilibrium is attained.
- (d) Both (b) and (c)

93 Choose the correct statement from the following.

- (a) Neglecting the small intermolecular forces in gas, its internal energy is just the sum of kinetic energies. associated with various random motion of its molecules.
- (b) A gas in a given state has a certain amount of heat.
- (c) A gas in a given state has a certain amount of work.
- (d) Both (b) and (c)

94 A system as shown in figure below, initially at state (p, T) is taken to state at (p', T') via a quasi-static process. Then, choose the correct statement.

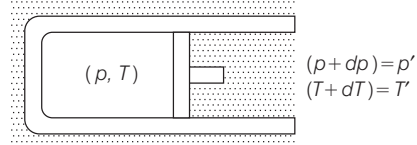

- (a) External pressure of the system should be changed abruptly.
- (b) Quasi-static process is not a hypothetical concept and can never be achieved by any way.
- (c) Temperature can be changed by introducing an infinite-simal temperature difference between the system and surrounding reservoir.
- (d) Various stages of the process will be in non-equilibrium state.

95 Choose the correct statement regarding isobaric process.

- (a) $pV = \text{constant}$.
- (b) Heat absorbed by the gas goes partly to increase internal energy and partly to do work.
- (c) The system returns to its initial state.
- (d) Both (a) and (b)

96 The p - V graph shown below, shows the cycle followed by an engine. In this, the curve 1 to 2 is isothermal, 2 to 3 is adiabatic and 3 to 1 is also adiabatic. **JEE Main 2014**

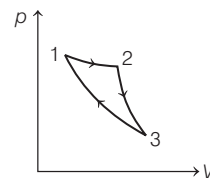

There is/are some condition(s) under which, this process does not exist. Choose the correct statement.

- (a) Heat is completely converted to mechanical energy in such a process, which is not possible.

- (b) Curves representing two adiabatic processes do not intersect.
 (c) Curves representing an adiabatic process and an isothermal process do not intersect.
 (d) Both (a) and (b)

97 Figure shows the p - V diagram of an ideal gas undergoing a change of state from A to B . Four different parts I, II, III and IV as shown in the figure may lead to the same change of state. Then, which of the following statement(s) is/are correct?

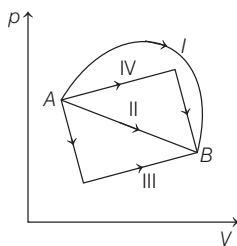

- (a) Change in internal energy is same in IV and III cases, but not in I and II.
 (b) Change in internal energy is same in all the four cases.
 (c) Work done is maximum in case III.
 (d) Work done is maximum in case II.

98 Which of the processes described below is/are reversible?

- (a) The increase in temperature of an iron rod by hammering it.
 (b) A gas in a small container at a temperature T_1 is brought in contact with a big reservoir at a higher temperature T_2 which increases the temperature of the gas.
 (c) A quasi-static isothermal expansion of an ideal gas in cylinder fitted with a frictionless piston.
 (d) An ideal gas is enclosed in a piston cylinder arrangement with adiabatic walls. A weight w is added to the piston resulting in compression of gas.

III. Matching Type

99. Match the Column I (quantity) with Column II (value) and select the correct answer from the codes given below.

Column I	Column II
A. 1 cal =	1. 4.186 J/gK
B. $p \left(\frac{\Delta V}{\Delta T} \right)_p =$	2. R
C. Specific heat capacity of solids	3. ΔQ
D. For isothermal process, ΔW	4. $3R$

- | | A | B | C | D |
|-----|---|---|---|---|
| (a) | 4 | 1 | 2 | 3 |
| (b) | 1 | 2 | 4 | 3 |
| (c) | 1 | 4 | 2 | 4 |
| (d) | 2 | 1 | 2 | 3 |

100 Match the Column I (thermodynamic process) with Column II (characteristic) and select the correct answer from the codes given below.

Column I	Column II
A. Isothermal	1. Volume constant
B. Isobaric	2. Temperature constant
C. Isochoric	3. No heat flow between the system and surrounding
D. Adiabatic	4. Pressure constant

- | | A | B | C | D | | A | B | C | D |
|-----|---|---|---|---|-----|---|---|---|---|
| (a) | 1 | 2 | 3 | 4 | (b) | 4 | 2 | 3 | 1 |
| (c) | 2 | 4 | 1 | 3 | (d) | 3 | 1 | 2 | 4 |

101 Thermodynamic processes are indicated in the following diagram

JEE Main 2019

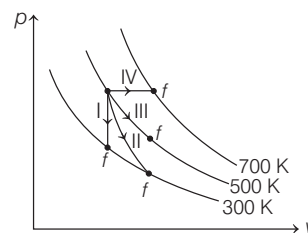

Match the Column I (process number) with Column II (process name) and select the correct answer from the codes given below.

Column I	Column II
A. Process I	1. Adiabatic
B. Process II	2. Isobaric
C. Process III	3. Isochoric
D. Process IV	4. Isothermal

- | | A | B | C | D | | A | B | C | D |
|-----|---|---|---|---|-----|---|---|---|---|
| (a) | 1 | 3 | 4 | 2 | (b) | 3 | 1 | 4 | 2 |
| (c) | 3 | 4 | 2 | 1 | (d) | 4 | 2 | 1 | 3 |

102 Match the Column I (parameter) with Column II (value or formula) for the process involved in refrigerator and heat pump given below and select the correct answer from the codes given below.

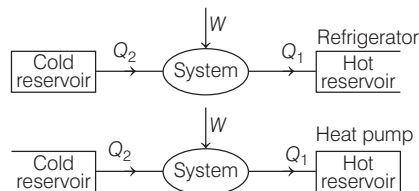

Column I	Column II
A. α for refrigerator	1. Q_1 / W
B. α for heat pump	2. Q_1 is heat given to the hot reservoir.
C. For a refrigerator	3. Q_2 / W
D. For a heat pump	4. Q_2 is heat given by the hot reservoir.

- | | A | B | C | D | | A | B | C | D |
|-----|---|---|---|---|-----|---|---|---|---|
| (a) | 3 | 2 | 1 | 4 | (b) | 1 | 3 | 4 | 2 |
| (c) | 3 | 1 | 2 | 4 | (d) | 3 | 1 | 2 | 2 |

NCERT & NCERT Exemplar

MULTIPLE CHOICE QUESTIONS

NCERT

- 103** What amount of heat must be supplied to 2.0×10^{-2} kg of nitrogen (at room temperature) to raise its temperature by 45°C at constant pressure? (Molecular mass of $\text{N}_2 = 28$, $R = 8.3 \text{ J mol}^{-1}\text{K}^{-1}$ and C_p for $\text{N}_2 = \frac{7}{2}R$).
- (a) 1033.55 J (b) 933.75 J
(c) 633.45 J (d) 233 J
- 104** A steam engine delivers $5.4 \times 10^8 \text{ J}$ of work per minute and services $3.6 \times 10^9 \text{ J}$ of heat per minute from the boiler. What is the efficiency of the engine and how much heat is wasted per minute?
- (a) 10%, $2 \times 10^5 \text{ J min}^{-1}$ (b) 10%, $3 \times 10^3 \text{ J min}^{-1}$
(c) 15%, $3.1 \times 10^9 \text{ J min}^{-1}$ (d) 15%, $3.1 \times 10^6 \text{ J min}^{-1}$
- 105** An electric heater supplies heat to a system at a rate of 100 W. If the system performs work at a rate of 75 Js^{-1} . At what rate is the internal energy increasing?
- (a) 30 Js^{-1} (b) 15 Js^{-1}
(c) 10 Js^{-1} (d) 25 Js^{-1}
- 106** A refrigerator is to remove heat from the eatable kept inside at 9°C . Calculate the coefficient of performance, if the room temperature is 36°C .
- (a) 20.9 (b) 10.4
(c) 11.2 (d) 31.8
- 107** A cylinder with a movable piston contains 3 mol of hydrogen at standard temperature and pressure. The walls of the cylinder are made of heat insulator and the piston is insulated by having a pile of sand on it. By what factor does the pressure of the gas increase, if the gas is compressed to half of its original volume?
- (a) 2.9 (b) 1.28
(c) 3.2 (d) 2.64
- Hint** : γ for hydrogen is 1.4

- 108** In changing the state of gas adiabatically from an equilibrium state A to another equilibrium state B , an amount of work equal to 22.3 J is done on the system. If the gas is taken from state A to B via a process in which the net heat absorbed by the system is 9.35 cal, how much is the net work done by the system in the later case? (Take, $1 \text{ cal} = 4.19 \text{ J}$)
- (a) 12.1 J (b) 16.9 J (c) 18.1 J (d) 13.7 J

- 109** A thermodynamic system is taken from an original state D to an intermediate state E by the linear process shown in figure below. Then, its volume is reduced to the original value from E to D via F by isobaric and isochoric process as shown by EF and FD , respectively. Calculate the total work done by the gas from D to E to F .

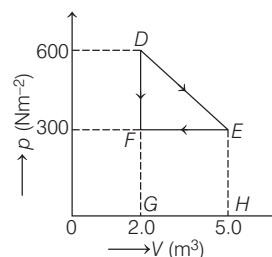

- (a) 150 J (b) 300 J
(c) 450 J (d) 350 J

NCERT Exemplar

- 110** An ideal gas undergoes four different processes from the same initial state (figure). Four processes are adiabatic, isothermal, isobaric and isochoric. Out of 1, 2, 3 and 4 which one is adiabatic?

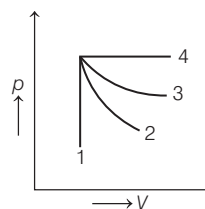

- (a) 4 (b) 3
(c) 2 (d) 1

- 111** Consider p - V diagram for an ideal gas shown in figure.

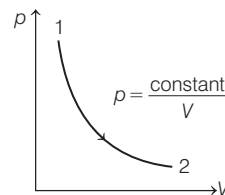

Out of the following diagrams, which figure represents the T - p diagram?

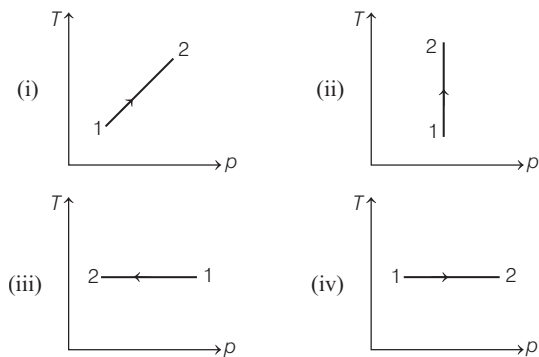

- (a) (iv) (b) (ii)
(c) (iii) (d) (i)

112 An ideal gas undergoes cyclic process $ABCD$ as shown in given p - V diagram. The amount of work done by the gas is **JEE Main 2013**

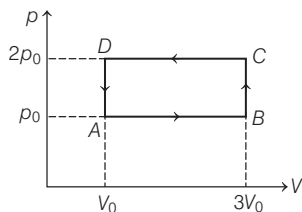

- (a) $6p_0V_0$ (b) $-2p_0V_0$
(c) $+2p_0V_0$ (d) $+4p_0V_0$

113 Consider two containers A and B containing identical gases at the same pressure, volume and temperature. The gas in container A is compressed to half of its original volume isothermally while the gas in container B is compressed to half of its original value adiabatically. The ratio of final pressure of gas in B to that of gas in A is

- (a) $2^{\gamma-1}$ (b) $\left(\frac{1}{2}\right)^{\gamma-1}$ (c) $\left(\frac{1}{1-\gamma}\right)^2$ (d) $\left(\frac{1}{\gamma-1}\right)^2$

114 Consider a Carnot cycle operating between $T_1 = 500$ K and $T_2 = 300$ K producing 1 kJ of mechanical work per cycle. Find the heat transferred to the engine by the reservoirs.

- (a) 1000 J (b) 2000 J (c) 1500 J (d) 2500 J

115 In a refrigerator, one removes heat from a lower temperature and deposits to the surroundings at a higher temperature. In this process, mechanical work has to be done, which is provided by an electric motor. If the motor is of 1 kW power and heat is transferred from -3°C to 27°C , find the heat taken out of the refrigerator per second, assuming its efficiency is 50% of a perfect engine.

- (a) 22 kJs $^{-1}$ (b) 19 kJs $^{-1}$
(c) 38 kJs $^{-1}$ (d) None of these

116 If the coefficient of performance of a refrigerator is 5 and operates at the room temperature (27°C), find the temperature inside the refrigerator.

- (a) -23°C (b) 23°C (c) 40°C (d) -40°C

Answers

> Mastering NCERT with MCQs

- | | | | | | | | | | |
|--------|--------|--------|--------|--------|--------|--------|--------|--------|--------|
| 1 (b) | 2 (d) | 3 (c) | 4 (b) | 5 (a) | 6 (d) | 7 (b) | 8 (a) | 9 (d) | 10 (d) |
| 11 (c) | 12 (d) | 13 (c) | 14 (d) | 15 (c) | 16 (c) | 17 (b) | 18 (b) | 19 (c) | 20 (d) |
| 21 (b) | 22 (c) | 23 (b) | 24 (d) | 25 (b) | 26 (d) | 27 (c) | 28 (c) | 29 (a) | 30 (b) |
| 31 (a) | 32 (a) | 33 (c) | 34 (d) | 35 (c) | 36 (d) | 37 (a) | 38 (a) | 39 (c) | 40 (c) |
| 41 (a) | 42 (c) | 43 (b) | 44 (a) | 45 (d) | 46 (b) | 47 (d) | 48 (b) | 49 (a) | 50 (c) |
| 51 (b) | 52 (d) | 53 (d) | 54 (a) | 55 (c) | 56 (b) | 57 (b) | 58 (b) | 59 (c) | 60 (c) |
| 61 (a) | 62 (a) | 63 (c) | 64 (b) | 65 (d) | 66 (c) | 67 (b) | 68 (b) | | |

> Special Types Questions

- | | | | | | | | | | |
|--------|---------|---------|---------|--------|--------|--------|--------|--------|--------|
| 69 (d) | 70 (d) | 71 (d) | 72 (a) | 73 (a) | 74 (b) | 75 (a) | 76 (b) | 77 (b) | 78 (c) |
| 79 (d) | 80 (d) | 81 (a) | 82 (a) | 83 (a) | 84 (c) | 85 (d) | 86 (d) | 87 (a) | 88 (d) |
| 89 (c) | 90 (d) | 91 (d) | 92 (d) | 93 (a) | 94 (c) | 95 (b) | 96 (d) | 97 (b) | 98 (c) |
| 99 (b) | 100 (c) | 101 (b) | 102 (d) | | | | | | |

> NCERT & NCERT Exemplar MCQs

- | | | | | | | | | | |
|---------|---------|---------|---------|---------|---------|---------|---------|---------|---------|
| 103 (b) | 104 (c) | 105 (d) | 106 (b) | 107 (d) | 108 (b) | 109 (c) | 110 (c) | 111 (c) | 112 (b) |
| 113 (a) | 114 (d) | 115 (b) | 116 (a) | | | | | | |

Hints & Explanations

- 3 (c)** Adiabatic or insulating walls do not allow flow of energy (heat) from one system to another, so no heat exchanges between systems A and B .
Thus, the thermodynamic states (pressure and temperature) of A and B will not change with time. It means both the systems will be in thermal equilibrium separately.
- 4 (b)** If two systems are in thermal equilibrium with each other, it means their temperatures are equal. However, their masses may be equal or unequal.
- 5 (a)** If a system is in thermodynamic equilibrium with its surroundings, it means that its state variables will not change with time, which is possible only when temperature of system and surroundings is same.
- 8 (a)** According to Zeroth law of thermodynamics, two systems in thermal equilibrium with a third system separately are in thermal equilibrium with each other.
So, if A and B are separately in equilibrium with C , then $T_A = T_C$ and $T_B = T_C$. This implies that $T_A = T_B$, i.e. the systems A and B are also in thermal equilibrium.
- 10 (d)** The internal energy of a gas contained in a movable box, depends only on the molecular energies, i.e. it is the sum of the kinetic energies and potential energies of the molecules of gas.
The kinetic energy of the moving box is not included in the internal energy.
Thus, internal energy does not depend on the speed v of the box.
- 11 (c)** When the cylinder is put in contact with a body at a higher temperature than that of gas, then the temperature difference will cause a flow of energy (heat) from hotter body to gas. This increases the internal energy of the gas.
Similarly, if we push the piston down, i.e. do some work on the system, it also results in increasing the internal energy of the gas.
Thus, internal energy or static of the gas can be changed by either of the ways mentioned in options (a) and (b).
- 12 (d)** Heat and work are two distinct modes of energy transfer to a system that results in change in its internal energy. Thus, either by extracting heat or doing work on the system or if work is done by system on surroundings, the internal energy of the system can be changed.
- 13 (c)** Heat and work in thermodynamics are not state variables. They are modes of energy transfer to a system resulting in change in its internal energy, which is a state variable.
- 14 (d)** Internal energy is a state variable which depends only on the state of the system, not on how that state was achieved. Thus, in the given case, internal energy of the ideal monoatomic gas would be same in all three ways taken by it to go from A to B .

- 15 (c)** For the given system,
Volume (V) = (l)(A)
Let piston moves a distance dl .
 $\Rightarrow dV = A dl$, for constant A ... (i)
Force on piston = (pressure) (area) = pA
So, work = force \times distance
 $= (pA)(dl) = p(A dl)$
 $dW = p dV$ [using Eq. (i)]
 $\Rightarrow \Delta W = p \Delta V$
Here, ΔW = finite work and dW = very small work.
- 16 (c)** Given, $dQ = +200 \text{ cal} = 200 \times 4.2 = 840 \text{ J}$
and $dW = +40 \text{ J}$
From first law of thermodynamics,
 $dQ = dU + dW$
 $dU = dQ - dW = 840 - 40 = 800 \text{ J}$
So, the internal energy of the system increases by 800 J .
- 17 (b)** Given, mass of water, $m = 1 \text{ g}$
Volume of 1 g of water = $1 \text{ cm}^3 = 10^{-6} \text{ m}^3$
Volume of 1 g of steam = $1671 \text{ cm}^3 = 1671 \times 10^{-6} \text{ m}^3$
Pressure, $p = 1 \times 10^5 \text{ Pa}$
Latent heat of vaporisation of water, $L = 2256 \text{ J/g}$
Change in volume,
 $\Delta V = (1671 - 1) \times 10^{-6} \text{ m}^3$
 $= 1670 \times 10^{-6} \text{ m}^3$... (i)
Heat supplied, $\Delta Q = mL = 1 \times 2256 = 2256 \text{ J}$... (ii)
As the steam expands, so the work done in expansion is
 $\Delta W = p \Delta V$
 $= 1 \times 10^5 \times 1670 \times 10^{-6}$ [from Eq. (i)]
 $= 167 \text{ J}$... (iii)
According to first law of thermodynamics,
 $\Delta Q = \Delta U + \Delta W$
 $\Rightarrow \Delta U = \Delta Q - \Delta W$
 $= 2256 - 167$ [from Eqs. (ii) and (iii)]
 $= 2089 \text{ J}$
- 18 (b)** According to the question,
Heat spent during the conversion of sample of water at 100°C to steam is
 $\Delta Q = 54 \text{ cal} = 54 \times 4.18 \text{ J}$
 $= 225.72 \text{ J}$
Normal pressure, $p = 1.013 \times 10^5 \text{ Nm}^{-2}$
Net work done during the conversion would be given as
 $\Delta W = p \Delta V$
 $= p[V_{\text{steam}} - V_{\text{water}}]$
Here, $V_{\text{steam}} = 167.1 \text{ cc} = 167.1 \times 10^{-6} \text{ m}^3$
 $V_{\text{water}} = 0.1 \text{ g} = 0.1 \text{ cc} = 0.1 \times 10^{-6} \text{ m}^3$

$$\begin{aligned}\therefore \Delta W &= 1.013 \times 10^5 [(167.1 - 0.1) \times 10^{-6}] \\ &= 1.013 \times 167 \times 10^{-1} = 16.917 \text{ J}\end{aligned}$$

Now, from first law of thermodynamics,

$$\Delta Q = \Delta U + \Delta W$$

where, ΔU is the change in internal energy of the sample.

$$\Rightarrow \Delta U = \Delta Q - \Delta W$$

Substituting the values in the above equation, we get

$$\begin{aligned}\Delta U &= 225.72 - 16.917 \\ &= 208.7 \text{ J}\end{aligned}$$

19 (c) As, heat capacity of a substance given as

$$\text{Heat capacity, } S = \frac{\text{Heat consumed by given mass}}{\text{Temperature raised}}$$

So, if given mass is increased or its temperature is decreased, then its heat capacity increases.

20 (d) Heat capacity per mole of the substance is given by

$$C = \frac{1}{\mu} \frac{\Delta Q}{\Delta T}$$

where, C is molar specific heat capacity of the substance.

It is independent of the amount of substance.

But it depends on the nature of the substance, its temperature and the condition under which heat is supplied.

23 (b) Here, $C_V = \frac{3}{2}R$

Since, $C_p - C_V = R$

$$\Rightarrow C_p = C_V + R = \frac{3}{2}R + R = \frac{5}{2}R$$

So, molar specific heat capacity at constant pressure = $\frac{5}{2}R$.

24 (d) Using first law of thermodynamics,

$$\Delta Q = \Delta U + p\Delta V$$

At constant V , $\Delta V = 0$

$$\Rightarrow C_V = \left(\frac{\Delta Q}{\Delta T}\right)_V = \left(\frac{\Delta U}{\Delta T}\right)_V$$

At constant pressure p , $\Delta p = 0$

$$\begin{aligned}C_p &= \left(\frac{\Delta Q}{\Delta T}\right)_p = \left(\frac{\Delta U}{\Delta T}\right)_p + \left(\frac{p\Delta V}{\Delta T}\right)_p \\ &= \left(\frac{\Delta U}{\Delta T}\right)_p + p\left(\frac{\Delta V}{\Delta T}\right)_p\end{aligned}$$

From ideal gas equation,

$$pV = \mu RT$$

For $\mu = 1$, $pV = RT$

At constant pressure p , $p\Delta V = R\Delta T$

$$p\left(\frac{\Delta V}{\Delta T}\right)_p = R$$

Thus, all the equations given in the options are correct for an ideal gas.

25 (b) At constant pressure,

$$\text{Heat required, } \Delta Q = nC_p\Delta T$$

$$\Rightarrow 310 = 2 \times C_p \times (35 - 25)$$

$$\Rightarrow C_p = \frac{310}{20} = 15.5 \text{ J/mol-K}$$

Similarly, at constant volume,

$$\text{Heat required, } \Delta Q = nC_V\Delta T$$

$$= 2(C_p - R) \times (35 - 25)$$

$$(\because C_p - C_V = R)$$

$$= 2 \times (15.5 - 8.3) \times 10$$

$$= 2 \times 7.2 \times 10 = 144 \text{ J}$$

26 (d) When a mixture of petrol vapour and air is ignited by a spark, then an explosive chemical reaction takes place. During the initial stage of this reaction the temperature and the pressure will not be uniform.

Thus, it represents a non-equilibrium state. Therefore, its initial state cannot be described by state variables.

However, with time the gas may attain a uniform temperature and pressure. Thus, it comes to thermal and mechanical equilibrium with time.

27 (c) Extensive state variables indicate the size of the system, whereas intensive do not.

So, if the system in equilibrium is divided into two equal parts, the variables that remain unchanged for each part are intensive.

On contrary, the variables whose values get halved in each part are extensive.

So, from the given values, we can say that U (internal energy) and M (mass) are extensive state variables and T (temperature) is an intensive state variable.

28 (c) Quasi-static process is nearly static (very slow) process, where every intermediate state of system is in equilibrium.

The system changes its variables (p , T and V), so slowly that it remains in thermal and mechanical equilibrium with its surroundings throughout.

This means, at every stage of the process, the difference in the p , V and T of the system and the external p , V and T is infinite-simally small.

29 (a) In an adiabatic process, the system is completely insulated from the surroundings. Thus, heat is neither absorbed nor released by the system to the surroundings. So, $\Delta Q = 0$.

If the pressure of gas is kept constant, then the process is called isobaric, i.e. $\Delta p = 0$.

If the temperature of the system remains constant, then it is called isothermal process, i.e. $\Delta T = 0$.

If the volume of gas is constant in a system, then it is called isochoric process, i.e. $\Delta V = 0$.

30 (b) In isothermal process of an ideal gas, $\Delta U = 0$

So, $\Delta Q = \Delta W$ (From first law of thermodynamics)

As the area under the curve represents the amount of the work done, i.e.

$$\Delta W = +20 \text{ J}$$

$$\Rightarrow \Delta Q = +20 \text{ J}$$

31 (a) For isothermal process, $pV = \text{constant}$.

Therefore, p - V graph is a rectangular hyperbola.

Since, $T_2 > T_1$

$$\Rightarrow (pV)_{\text{at } T_2} > (pV)_{\text{at } T_1}$$

Thus, the graph given in option (a) correctly represents the given situation.

32 (a) In isothermal process, temperature is constant.

From ideal gas equation, $pV = \mu RT$

At constant temperature, $pV = \text{constant}$

So, with decreasing pressure p , V must increase to keep product pV constant. This inverse relation between p and V is depicted correctly by curve A , where p decreases with increasing V .

33 (c) In isothermal expansion, $V_2 > V_1$

As, work done in an isothermal process is given by

$$\Delta W = \mu RT \ln \frac{V_2}{V_1}$$

\Rightarrow In this case, $\Delta W_1 > 0 \Rightarrow \Delta W_1 = +ve$

Similarly, in isothermal compression, $V_1 > V_2$

$\Rightarrow \Delta W_2 < 0$

$\Rightarrow \Delta W_2 = -ve$

34 (d) Given, $\mu = 10 \text{ mol}$, $T = 500 \text{ K}$,

$$V_1 = 50 \text{ L and } V_2 = 5 \text{ L}$$

Work done at constant temperature (i.e. isothermal process),

$$\begin{aligned} W &= 2.3\mu RT \log_{10} \left(\frac{V_2}{V_1} \right) \\ &= 2.3 \times 10 \times 8.31 \times 500 \times \log_{10} \left(\frac{5}{50} \right) \\ &= -9.5565 \times 10^4 \text{ J} \\ &\approx -9.6 \times 10^4 \text{ J} \end{aligned}$$

35 (c) In adiabatic process, heat remains constant. So, from first law of thermodynamics

$$\Delta Q = \Delta U + \Delta W$$

$\Rightarrow \Delta U + \Delta W = 0$

When work is done on system, $\Delta W = -ve$

$\Rightarrow \Delta U = -\Delta W = +ve$

As, $\Delta U = \mu C_V \Delta T = +ve \Rightarrow \Delta T = +ve$

$\Rightarrow T$ increases or $T_f > T_i$.

36 (d) For adiabatic process, $pV^\gamma = TV^{\gamma-1} = \text{constant}$

$$\Rightarrow \frac{T_1}{T_2} = \left(\frac{V_2}{V_1} \right)^{\gamma-1}$$

Here, $T_2 = 2T_1$ and $V_2 = \frac{V_1}{2}$

$$\left(\frac{1}{2} \right)^{\gamma-1} = \left(\frac{1}{2} \right)$$

$\Rightarrow \gamma - 1 = 1$ or $\gamma = 2$

$\Rightarrow pV^\gamma = pV^2 = \text{constant}$

37 (a) For adiabatic change, the equation of state is

$$pV^\gamma = \text{constant}$$

Also, for ideal gas,

$$pV = \mu RT$$

$$\Rightarrow V = \frac{\mu RT}{p}$$

$$\text{So, } p \left(\frac{\mu RT}{p} \right)^\gamma = \text{constant}$$

$$\Rightarrow \frac{p}{p^\gamma} T^\gamma = \frac{\text{constant}}{(\mu R)^\gamma} = \text{constant}$$

$$\Rightarrow p^{1-\gamma} T^\gamma = \text{constant}$$

38 (a) In an adiabatic process,

$$pV^\gamma = \text{constant} = k \text{ (say)}$$

where, p is pressure, V is volume and γ is ratio of the specific heats.

$$\text{Given, } \frac{C_p}{C_v} = \gamma = \frac{3}{2}$$

$$\therefore pV^{3/2} = k$$

Taking logarithm of both sides, we get

$$\log p + \frac{3}{2} \log V = \log k$$

$$\therefore \frac{\Delta p}{p} + \frac{3}{2} \frac{\Delta V}{V} = 0$$

$$\Rightarrow \frac{\Delta V}{V} = -\frac{2}{3} \frac{\Delta p}{p}$$

$$\begin{aligned} \Rightarrow \frac{\Delta V}{V} \times 100 &= -\frac{2}{3} \left(\frac{\Delta p}{p} \times 100 \right) \\ &= -\frac{2}{3} \times \frac{2}{3} = -\frac{4}{9}\% \end{aligned}$$

Negative sign implies that volume decreases by $\frac{4}{9}\%$.

39 (c) Given, for diatomic gas, $\gamma = \frac{7}{5}$

For adiabatic process, $TV^{\gamma-1} = \text{constant}$

$$T_1 V_1^{\gamma-1} = T_2 V_2^{\gamma-1}$$

Given, $V_2 = \frac{V_1}{5}$ and $T_1 = 27^\circ \text{C} = 300 \text{ K}$

(at standard conditions)

$$(300) V_1^{\frac{7}{5}-1} = T_2 \left(\frac{V_1}{5} \right)^{\frac{7}{5}-1}$$

$$\Rightarrow T_2 = \frac{300 \times V_1^{2/5}}{V_1^{2/5} \times \left(\frac{1}{5} \right)^{2/5}} = \frac{300}{5^{2/5}} = 300 \times 5^{2/5}$$

$$= 300 \times 1.903 = 571 \text{ K}$$

Mean kinetic energy of rotating molecules

$$= kT = 1.38 \times 10^{-23} \times 571 = 787.98 \times 10^{-23} \text{ J}$$

40 (c) Slope of isothermal curve

$$= -\tan \phi = \frac{dp}{dV} = -\frac{p}{V}$$

[∵ for isothermal process, $pV = \text{constant}$

$$\Rightarrow p dV + V dp = 0 \text{ or } \frac{dp}{dV} = -\frac{p}{V}]$$

Similarly, slope of adiabatic curve,

$$-\tan \phi = \frac{d}{dV} \left(\frac{\text{constant}}{V^\gamma} \right) = -\gamma \left(\frac{p}{V} \right)$$

[∵ for adiabatic process, $pV^\gamma = \text{constant}$]

As we know, $\gamma > 1$

Thus, (slope)_{adiabatic} > (slope)_{isothermal}

41 (a) The solution of this question can be understood by plotting a p - V graph for the compression of a gas isothermally and adiabatically simultaneously to half of its initial volume, i.e.

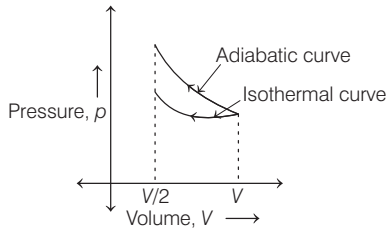

Since, the isothermal curve is less steeper than the adiabatic curve. So, area under the (p - V) curve for adiabatic process has more magnitude than isothermal curve. Hence, work done in adiabatic process will be more than in isothermal process.

42 (c) Isochoric process takes place at constant volume.

Since, there is no change of volume ($\Delta V = 0$), therefore work done in this process, $\Delta W = p \Delta V = 0$.

43 (b) Work done at constant pressure is

$$W = p \Delta V = \mu R \Delta T$$

where, p is pressure, ΔV is the volume change, R is the gas constant, ΔT is the change in temperature and μ is the number of moles.

Given, $\mu = 1$, $T_1 = 27^\circ \text{C} = 300 \text{K}$

and $T_2 = 127^\circ \text{C} = 400 \text{K}$

$$R = 8.31 \text{ J/mol-K}$$

$$\therefore W = 1 \times 8.31 \times (400 - 300)$$

$$\Rightarrow W = 831 \text{ J}$$

44 (a) Ideal gas equation, at constant pressure is given by

$$p \Delta V = nR \Delta T \quad \dots \text{(i)}$$

$$\therefore \text{Work done, } W = p \Delta V \quad \dots \text{(ii)}$$

$$W = nR \Delta T$$

At constant pressure, heat given to gas is given by

$$Q = nC_p \Delta T \quad \dots \text{(iii)}$$

where, C_p = specific heat at constant pressure.

From Eqs. (ii) and (iii), we get

$$\frac{W}{Q} = \frac{nR \Delta T}{nC_p \Delta T} = \frac{R}{C_p} = \frac{R}{(7/2)R} = \frac{2}{7}$$

Given, $W = 10 \text{ J}$

$$\Rightarrow \frac{10}{Q} = \frac{2}{7} \Rightarrow Q = 35 \text{ J}$$

45 (d) At first, the gas undergoes isothermal expansion from V to $3V$. For such a process, the equation of gas will be

$$pV = \text{constant.}$$

This means pressure is inversely proportional to volume. Thus, p - V curve for such a process will be as shown.

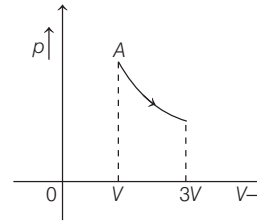

After that, its volume is decreased or reduced from $3V$ to V at constant pressure. Thus, the final p - V curve for this ideal gas will be as shown

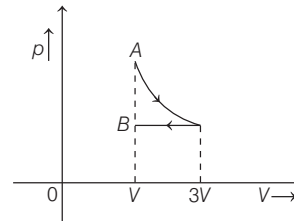

Thus, the graph given in option (d) is correctly representing the given situation.

46 (b) As we know, for a thermodynamic process, area under the p - V curve for the process gives the work done. So according to the given figure,

$$W_{AB} = \frac{1}{2} (p_0 + 3p_0) (2V_0 - V_0) = 2p_0V_0$$

$$W_{BC} = 3p_0(V_0 - 2V_0) = -3p_0V_0$$

$$W_{CD} = \frac{1}{2} (3p_0 + p_0) (2V_0 - V_0) = 2p_0V_0$$

$$W_{DA} = p_0(V_0 - 2V_0) = -p_0V_0$$

Net work done,

$$W = 2p_0V_0 - 3p_0V_0 + 2p_0V_0 - p_0V_0 = 0$$

47 (d) According to given figure as shown below

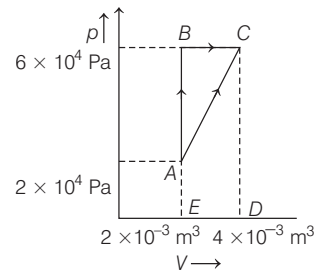

Process AB is isochoric, i.e. $\Delta V = 0$, so no work is done.

Heat added to the system in the process AB is

$$\Delta Q = 400 \text{ J}$$

According to first law of thermodynamics,

$$\Delta Q = \Delta U + \Delta W$$

where, ΔU is the change in internal energy and ΔW is the work done.

Since, $\Delta W = 0 \Rightarrow \Delta U = \Delta Q = 400 \text{ J}$

\therefore Change in internal energy is 400 J.

Process BC is isobaric and the work done is given by

$$\begin{aligned} \Delta W &= p(V_2 - V_1) \\ &= 6 \times 10^4 (4 \times 10^{-3} - 2 \times 10^{-3}) \\ &= 6 \times 10^4 \times 2 \times 10^{-3} = 120 \text{ J} \end{aligned}$$

Heat added to the system in the process BC is

$$\Delta Q = 100 \text{ J}$$

Since, $\Delta Q = \Delta U + \Delta W$

$$\Delta U = \Delta Q - \Delta W = (100 - 120) \text{ J} = -20 \text{ J}$$

\therefore Change in internal energy is -20 J .

Total increase in internal energy is going from state A to state C is $400 - 20 = 380 \text{ J}$.

Work done in process AC is the area under the curve.

Area of the trapezium $ACDEA$

$$\begin{aligned} &= \frac{1}{2} (p_2 + p_1) \times (V_2 - V_1) \\ &= \frac{1}{2} (6 \times 10^4 + 2 \times 10^4) \times (4 \times 10^{-3} - 2 \times 10^{-3}) \\ &= \frac{1}{2} \times 8 \times 10^4 \times 2 \times 10^{-3} = 80 \text{ J} \end{aligned}$$

Again, by using $\Delta Q = \Delta U + \Delta W$,

where $\Delta U = 380 \text{ J}$ and $\Delta W = 80 \text{ J}$

$$\begin{aligned} \therefore \Delta Q &= \Delta U + \Delta W \\ &= 380 + 80 = 460 \text{ J} \end{aligned}$$

Thus, the heat absorbed by the system in the process AC will be 460 J.

48 (b) In Process $a \rightarrow b$

$$\begin{aligned} \text{Given, } \Delta Q_{ab} &= 250 \text{ J} \\ \therefore 250 \text{ J} &= \Delta U_{ab} + dW_{ab} \quad \dots(\text{ii}) \end{aligned}$$

In Process $b \rightarrow c$

$$\begin{aligned} \text{Given, } \Delta Q_{bc} &= 60 \text{ J} \\ \text{Also, } V \text{ is constant, so } dV &= 0 \\ \Rightarrow dW_{bc} &= p(dV)_{bc} = 0 \quad \dots(\text{iii}) \\ \therefore 60 \text{ J} &= \Delta U_{bc} + 0 \\ \Rightarrow \Delta U_{bc} &= 60 \text{ J} \end{aligned}$$

In Process $c \rightarrow a$

$$\text{Given, } \Delta U_{ca} = -180 \text{ J} \quad \dots(\text{iv})$$

Now, for complete cycle,

$$\Delta U_{abca} = \Delta U_{ab} + \Delta U_{bc} + \Delta U_{ca} = 0 \quad \dots(\text{v})$$

From Eqs. (iii), (iv) and (v), we get

$$\Delta U_{ab} = -\Delta U_{bc} - \Delta U_{ca}$$

$$\Delta U_{ab} = -60 + 180 = 120 \text{ J} \quad \dots(\text{vi})$$

From Eq. (ii), we get

$$250 \text{ J} = 120 \text{ J} + dW_{ab}$$

$$\Rightarrow dW_{ab} = 130 \text{ J} \quad \dots(\text{vii})$$

From Eqs. (i) and (vii), we get

Work done by the gas along the path abc ,

$$\begin{aligned} dW_{abc} &= dW_{ab} + dW_{bc} \\ &= 130 \text{ J} + 0 \text{ J} \end{aligned}$$

$$\Rightarrow dW_{abc} = 130 \text{ J}$$

49 (a) As, $W_{CB} = p\Delta V = nR\Delta T = -nR(2T_0 - T_0) = -nRT_0$

$$W_{BA} = p\Delta V = 0 \quad (\because \Delta V = 0)$$

$$\text{and } W_{AC} = nRT \ln \left(\frac{V_2}{V_1} \right) = 2nRT_0 \ln \left(\frac{2V_0}{V_0} \right)$$

$$= +2nRT_0 \ln 2$$

$$\text{Work done} = W_{AC} + W_{CB} + W_{BA}$$

$$= 2nRT_0 \ln 2 - nRT_0 + 0$$

$$= nRT_0(2\ln 2 - 1)$$

$$\text{Also, input heat, } \Delta Q_{BC} = nC_p \Delta T = \frac{nR\gamma T_0}{\gamma - 1}$$

$$\therefore \text{Efficiency} = \frac{\text{Work done}}{\text{Input heat}} = \frac{(2\ln 2 - 1)}{\gamma/(\gamma - 1)}$$

50 (c) According to the first law of thermodynamics,

Heat supplied (ΔQ) = Work done (W) + Change in internal energy of the system (ΔU)

$$\Delta Q_A = \Delta U_A + W_A$$

Similarly, for process B ,

$$\Delta Q_B = \Delta U_B + W_B$$

Now, we know that,

work done for a process = area under its p - V curve

Here,

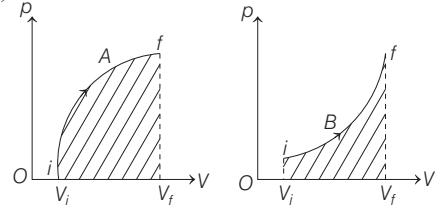

Thus, it is clear from the above graphs,

$$W_A > W_B \quad \dots(\text{i})$$

Also, since the initial and final state are same in both process, so

$$\Delta U_A = \Delta U_B \quad \dots(\text{ii})$$

So, from Eqs. (i) and (ii), we can conclude that

$$\Delta Q_A > \Delta Q_B$$

52 (d) According to the given heat engine, it takes heat Q_1

from a hot reservoir at temperature T_1 , releases heat Q_2 to a cold reservoir at temperature T_2 and delivers work to the surroundings/environment.

Since, heat engine is a device by which a system is made to undergo a cyclic process that results in conversion of heat to work.

Thus, according to first law of thermodynamics, for one complete cycle,

$$W = Q_1 - Q_2$$

Also, efficiency η of a heat engine is defined by

$$\eta = \frac{W}{Q_1}$$

Therefore, η decreases with increase in Q_1 .

Hence, all the given options are correct regarding the heat engine.

- 53 (d)** Considering the figure, we can write $Q_1 = W + Q_2$
 $\Rightarrow W = Q_1 - Q_2 > 0$ (given)
 $\Rightarrow Q_1 > Q_2 > 0$ (if both Q_1 and Q_2 are positive)
 We can also write $Q_2 < Q_1 < 0$ (if both Q_1 and Q_2 are negative)

- 54 (a)** Efficiency, $\eta = \frac{\text{Work done}}{\text{Heat input}} \times 100$
 or $\frac{\eta}{100} = \frac{\text{Work done}}{\text{Heat input}} = \frac{500}{\text{Heat input}}$
 $\Rightarrow \text{Heat input} = \frac{500 \times 100}{50} = 1000 \text{ J}$

- 55 (c)** Efficiency of an ideal heat engine is given as

$$\eta = 1 - \frac{T_2}{T_1}$$

where, T_1 is the temperature of the source and T_2 is the temperature of the sink.

Here, $T_1 = 100 + 273 = 373 \text{ K}$ (At boiling point)

$T_2 = 0 + 273 = 273 \text{ K}$ (At freezing point)

$$\Rightarrow \eta = 1 - \frac{273}{373} = \frac{373 - 273}{373} = \frac{100}{373} = 0.268$$

$$\therefore \eta \% = 0.268 \times 100 = 26.8 \%$$

- 56 (b)** \therefore Efficiency of a heat engine,

$$\eta = 1 - \frac{T_2}{T_1} \text{ or } \frac{1}{6} = 1 - \frac{T_2}{T_1}$$

$$\Rightarrow \frac{T_2}{T_1} = 1 - \frac{1}{6} = \frac{5}{6} \Rightarrow T_2 = \frac{5T_1}{6} \quad \dots(i)$$

According to question, its efficiency is doubled when temperature of sink decreased by 62°C .

$$\therefore 2\eta = 1 - \frac{T_2 - 62}{T_1}$$

$$\Rightarrow 2\left(\frac{1}{6}\right) = 1 - \frac{\left(\frac{5T_1}{6} - 62\right)}{T_1} \quad [\text{from Eq. (i)}]$$

$$\Rightarrow \frac{5T_1}{6} - 62 = T_1 \left(1 - \frac{2}{6}\right) = \frac{2T_1}{3}$$

$$\Rightarrow \frac{5T_1}{6} - \frac{2T_1}{3} = 62 \Rightarrow \frac{T_1}{6} = 62$$

$$\Rightarrow T_1 = 372^\circ\text{C}$$

- 58 (b)** Given, temperature of source,

$$T_1 = 30^\circ\text{C} = 30 + 273$$

$$T_1 = 303 \text{ K}$$

Temperature of sink, $T_2 = 4^\circ\text{C} = 4 + 273$

$$T_2 = 277 \text{ K}$$

As, we know that, for an ideal refrigerator,

$$\frac{Q_1}{Q_2} = \frac{T_1}{T_2} \Rightarrow \frac{Q_2 + W}{Q_2} = \frac{T_1}{T_2} \quad (\because W = Q_1 - Q_2)$$

where, Q_2 is the amount of heat drawn from the sink (at T_2), W is work done on working substance and Q_1 is the amount of heat rejected to source (at room temperature T_1).

$$\Rightarrow WT_2 + T_2Q_2 = T_1Q_2$$

$$\Rightarrow WT_2 = T_1Q_2 - T_2Q_2$$

$$\Rightarrow WT_2 = Q_2(T_1 - T_2)$$

$$\Rightarrow W = Q_2 \left(\frac{T_1}{T_2} - 1 \right)$$

$$\Rightarrow W = 600 \times 4.2 \times \left(\frac{303}{277} - 1 \right)$$

$$\Rightarrow W = 600 \times 4.2 \times \left(\frac{26}{277} \right)$$

$$\Rightarrow W = 236.5 \text{ J}$$

$$\therefore \text{Power} = \frac{\text{Work done}}{\text{Time}} = \frac{W}{t} = \frac{236.5}{1} = 236.5 \text{ W}$$

- 59 (c)** Given that, the temperature of freezer, $T_2 = -13^\circ\text{C}$

$$\Rightarrow T_2 = -13 + 273 = 260 \text{ K}$$

Coefficient of performance, $\alpha = 5$

The coefficient of performance is defined as

$$\alpha = \frac{\text{heat extracted}}{\text{work done}} = \frac{Q_2}{Q_1 - Q_2} = \frac{T_2}{T_1 - T_2}$$

$$\Rightarrow 5 = \frac{260}{T_1 - 260} \Rightarrow T_1 - 260 = \frac{260}{5}$$

$$\text{or } T_1 - 260 = 52 \Rightarrow T_1 = (52 + 260) \text{ K} = 312 \text{ K}$$

$$\Rightarrow T_1 = (312 - 273)^\circ\text{C}$$

$$\therefore T_1 = 39^\circ\text{C}$$

- 60 (c)** Coefficient of performance (α) of refrigerator is defined as heat extracted per unit work done, i.e.

$$\alpha = \frac{Q_2}{W} = \frac{\text{Heat extracted}}{\text{Work done}}$$

Here, $Q_1 = W + Q_2 =$ heat released to hot reservoir

$$\Rightarrow Q_2 = Q_1 - W$$

$$\Rightarrow \alpha = \frac{Q_1 - W}{W} = \frac{t_2}{t_1 - t_2}$$

$$\Rightarrow \frac{Q_1 - W}{W} = \frac{t_2 + 273}{(t_1 + 273) - (t_2 + 273)} = \frac{t_2 + 273}{t_1 - t_2}$$

$$\text{So, } \frac{Q_1 - W}{W} = \frac{t_2 + 273}{t_1 - t_2} \Rightarrow \frac{Q_1}{W} - 1 = \frac{t_2 + 273}{t_1 - t_2}$$

Thus, the amount of heat delivered to the room for each joule of energy consumed,

$$\frac{Q_1}{W} = \frac{t_2 + 273}{t_1 - t_2} + 1 = \frac{t_1 + 273}{t_1 - t_2}$$

61 (a) Second law of thermodynamics gives a fundamental limitation to the efficiency of a heat engine and the coefficient of performance of a refrigerator.

According to which heat engine cannot have efficiency equal to 1.

and a refrigerator cannot have infinite value of coefficient of performance.

Thus, a heat engine cannot fully convert heat into work.

63 (c) For Carnot engine during temperature change process, no heat should be absorbed or released from reservoirs. So, it should be adiabatic process.

64 (b) Total work done by the gas,

$$W_{\text{total}} = W_{A \rightarrow B} + W_{B \rightarrow C} + W_{C \rightarrow D} + W_{D \rightarrow A}$$

By observing the isothermal process $A \rightarrow B$, we can find that work done by the gas,

$$W_{\text{iso}} \text{ by gas} = \mu R T \log \frac{V_f}{V_i} \Rightarrow W = \mu R T_1 \log \left(\frac{V_2}{V_1} \right) \dots \text{(i)}$$

Here, W is positive as $V_2 > V_1$.

By observing the adiabatic process $B \rightarrow C$, we can find that work done by the gas,

$$W_{\text{adia}} \text{ by gas} = \frac{\mu R (T_i - T_f)}{\gamma - 1} \Rightarrow W = \frac{\mu R (T_1 - T_2)}{(\gamma - 1)} \dots \text{(ii)}$$

Here, W is positive as T_2 is less than T_1 .

By observing the isothermal process $C \rightarrow D$, we can find that work done on the gas,

$$W_{\text{iso}} \text{ on gas} = \mu R T_2 \log \left(\frac{V_4}{V_3} \right)$$

$$\Rightarrow W = -\mu R T_2 \log \left(\frac{V_3}{V_4} \right) \dots \text{(iii)}$$

By observing the adiabatic process $D \rightarrow A$, we can find that work done on the gas,

$$W_{\text{adia}} \text{ on gas} = \frac{\mu R (T_2 - T_1)}{\gamma - 1}$$

$$W = -\mu R \frac{(T_1 - T_2)}{\gamma - 1} \dots \text{(iv)}$$

Adding Eqs. (i), (ii), (iii) and (iv), we get

$$\Rightarrow W_{\text{total}} = \mu R T_1 \log \frac{V_2}{V_1} - \mu R T_2 \log \frac{V_3}{V_4}$$

65 (d) Carnot engines given are operating in cascade configuration as shown in the figure.

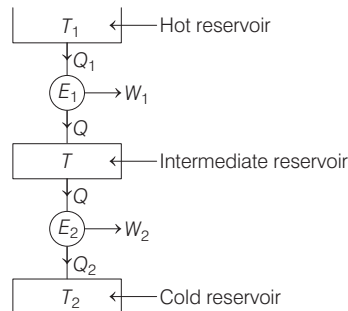

Work done by engine 1,

$$W_1 = Q_1 - Q = k(T_1 - T)$$

Work done by engine 2,

$$W_2 = Q - Q_2 = k(T - T_2)$$

$$\text{So, } \frac{W_1}{W_2} = \frac{T_1 - T}{T - T_2}$$

$$\text{As, } \frac{W_1}{W_2} = 1 \quad \text{(given)}$$

$$\Rightarrow T - T_2 = T_1 - T \Rightarrow T = \frac{T_1 + T_2}{2}$$

66 (c) Given, $Q_1 = 6 \times 10^5 \text{ cal}$

$$T_1 = 227^\circ \text{C} = 227 + 273 = 500 \text{K}$$

$$T_2 = 127^\circ \text{C} = 127 + 273 = 400 \text{K}$$

Work done per cycle, $W = ?$

$$\text{As, } \frac{Q_2}{Q_1} = \frac{T_2}{T_1}$$

$$\Rightarrow Q_2 = \frac{T_2}{T_1} \times Q_1 = \frac{400}{500} \times 6 \times 10^5 = 4.8 \times 10^5 \text{ cal}$$

$$\text{As, } W = Q_1 - Q_2 = 6 \times 10^5 - 4.8 \times 10^5$$

$$W = 1.2 \times 10^5 \text{ cal} = 1.2 \times 10^5 \times 4.2 \text{ J}$$

$$W = 5.04 \times 10^5 \text{ J} \approx 5 \times 10^5 \text{ J}$$

67 (b) Efficiency of a Carnot engine working between source of temperature T_1 and sink of temperature T_2 is given by

$$\eta = 1 - \frac{T_2}{T_1}$$

Here, T_2 and T_1 are absolute temperatures.

Initially,

$$\eta = \frac{1}{6}$$

$$\therefore \frac{1}{6} = 1 - \frac{T_2}{T_1} \Rightarrow \frac{T_2}{T_1} = \frac{5}{6}$$

Finally, efficiency is doubled on reducing sink temperature by 62°C .

$$\therefore \eta = \frac{2}{6}, T_{\text{sink}} = T'_2 = T_2 - 62$$

$$\text{So, } \eta = 1 - \frac{T'_2}{T_1}$$

$$\Rightarrow \frac{2}{6} = 1 - \frac{T_2 - 62}{T_1} \Rightarrow \frac{T_2 - 62}{T_1} = \frac{4}{6}$$

$$\Rightarrow \frac{T_2}{T_1} - \frac{62}{T_1} = \frac{4}{6} \Rightarrow \frac{5}{6} - \frac{62}{T_1} = \frac{4}{6}$$

$$\left[\because \frac{T_2}{T_1} = \frac{5}{6} \right]$$

$$\Rightarrow T_1 = 6 \times 62 = 372 \text{ K} = 372 - 273 = 99^\circ \text{C}$$

$$\Rightarrow T_2 = \frac{5}{6} \times T_1 \approx 310 \text{ K}$$

$$= 310 - 273 = 37^\circ \text{C}$$

- 68 (b)** Consider schematic diagram for a Carnot engine as shown below

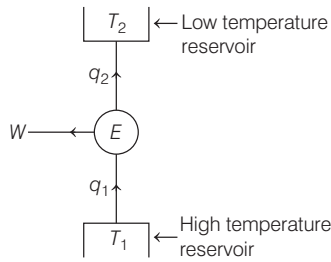

In case of engine,

$$\text{engine efficiency} = \frac{\text{work}}{\text{heat absorbed}} = \frac{W}{q_1}$$

$$\therefore \frac{W}{q_1} = \frac{1}{10} \Rightarrow \frac{10 \text{ J}}{q_1} = \frac{1}{10} \Rightarrow q_1 = 100 \text{ J}$$

When this engine is reversed, it takes in work W and heat q_2 from cold reservoir and ejects 100 J of heat to hot reservoir.

$$\therefore W + q_2 = q_1$$

$$\Rightarrow 10 + q_2 = 100 \text{ or } q_2 = 90 \text{ J}$$

- 69 (d)** Specific heat capacity $s = \frac{\Delta Q}{m \Delta T}$, where m is mass of substance. Its SI unit is $\text{J kg}^{-1} \text{K}^{-1}$.

Molar specific heat capacity $C = \frac{\Delta Q}{\mu \Delta T}$, where μ is number of moles. Its SI unit is $\text{J mol}^{-1} \text{K}^{-1}$.

Both of these are constants characteristics of a substance and are independent of its mass.

Therefore, Assertion is incorrect but Reason is correct.

- 70 (d)** In equation $\Delta Q = \Delta U + p \Delta V$, quantities on both sides are extensive. This is because, ΔQ is clearly proportional to the total mass of the system and hence it is extensive. On the right hand side, ΔU is an extensive variable. Also, the product of an intensive variable like p and an extensive quantity ΔV is extensive.

Therefore, Assertion is incorrect but Reason is correct.

- 71 (d)** As there is no change in internal energy of the system during an isothermal change. So, the energy taken by the gas is utilised by doing work against external pressure.

According to first law of thermodynamics,

$$\Delta Q = \Delta U + \Delta W$$

$$\text{As, } \Delta U = 0 \Rightarrow \Delta Q = \Delta W$$

Hence, whole heat energy supplied to the body in an isothermal process is converted into work done.

Therefore, Assertion is incorrect but Reason is correct.

- 72 (a)** In adiabatic process, heat transfer to the thermodynamic system is zero, i.e. $\Delta Q = 0$.

Hence, by first law of thermodynamics,

$$Q = 0 = \Delta U + \Delta W$$

$$\therefore W = -\Delta U$$

So, work done is equal to negative of change in internal energy.

Since, the internal energy is a function of thermodynamic state of the system.

It does not depend on the path, therefore work done is also independent of path in adiabatic process.

Therefore, Assertion and Reason are correct and Reason is the correct explanation of Assertion.

- 73 (a)** In an isochoric process, volume is constant. So, work done $\Delta W = p \Delta V = 0$

Thus, according to first law of thermodynamics,

$$\Delta Q = \Delta U + \Delta W \Rightarrow \Delta Q = \Delta U$$

Therefore, heat absorbed by the gas goes entirely to change its internal energy and its temperature.

Therefore, Assertion and Reason are correct and Reason is the correct explanation of Assertion.

- 74 (b)** In cyclic process, the system returns to its initial state as shown below, so $\Delta U = 0$.

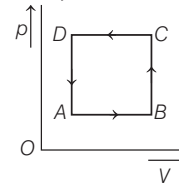

However, reversibility is a hypothetical concept which means a process is reversible, if it can be turned back such that both the system and surroundings return to their original state, with no other change anywhere else in universe. In cyclic process $A \rightarrow B \rightarrow C \rightarrow D \rightarrow A$, the system returns back its temperature, pressure, volume at A its (initial state) but some work is done on system (in given figure) and system releases heat. Work done on the system is not reversed back (i.e. system has not done work on surroundings). Thus, reversibility has nothing to do with cyclic process.

Therefore, Assertion and Reason are correct but Reason is not the correct explanation of Assertion.

- 75 (a)** Coefficient of performance of a refrigerator,

$$\alpha = \frac{Q_2}{W} \quad \dots(i)$$

where, Q_2 is the heat extracted from the cold reservoir and W is the work done on the system (the refrigerant). Since, in a heat engine, heat cannot be fully converted into work. Likewise, a refrigerator cannot work without some external work done.

Thus, α can never be infinite.

Therefore, Assertion and Reason are correct and Reason is the correct explanation of Assertion.

- 76 (b)** The first law of thermodynamics is the general law of conservation of energy applied to any system in which energy transfer from or to the surrounding (through heat and work) is taken into account.

The second law of thermodynamics disallows some process consistent with the first law of thermodynamics. It states that

No process is possible whose sole result is the absorption of heat from a reservoir and complete conversion of heat into work (Kelvin-Planck statement).
 No process is possible whose sole result is the transfer of heat from a colder object to a hotter object (Clausius statement).

Therefore, Assertion and Reason are correct but Reason is not the correct explanation of Assertion.

- 77 (b)** Irreversibility mainly arises due to
 (i) dissipative factor like friction, viscosity, etc
 (ii) and as many processes takes the system to non-equilibrium state.

So, when the blade is rotated in a liquid, then due to the viscosity, the system becomes irreversible as it stops after a certain time.

Thus, it is a irreversible process.

Therefore, Assertion and Reason are correct but Reason is not the correct explanation of Assertion.

- 78 (c)** Efficiency of Carnot engine, $\eta = 1 - \frac{T_2}{T_1}$

where, T_2 = sink temperature
 and T_1 = source temperature.

This expression of η does not include working substance information.

So, η is independent of working substance.

\therefore Reversible Carnot engine with one particular substance cannot be more efficient than the one using another substance because it does not matter what substance is being used.

Therefore, Assertion is correct but Reason is incorrect.

- 79 (d)** A reversible heat engine operating between two temperature is called a Carnot engine. The efficiency of this engine is maximum but not 100%.

Efficiency of Carnot engine,

$$\eta = 1 - \frac{T_2}{T_1}, \text{ here } T_1 \text{ and } T_2 \text{ are in kelvin.}$$

or
$$\eta = 1 - \frac{Q_2}{Q_1}$$

As all heat supplied cannot be fully converted to work (by second law of thermodynamics).

So, $Q_2 \neq 0 \Rightarrow \eta \neq 1$, i.e. $\eta \neq 100\%$.

Therefore, Assertion is incorrect but Reason is correct.

- 80 (d)** Let us consider I absorb heat Q_1 from source, deliver work W' and release the heat $Q_1 - W'$ to sink. R is then arranged in such a way that it returns same heat Q_1 to the source, taking heat Q_2 from the sink, requiring work $W = Q_1 - Q_2$ is to be done on it.

If $\eta_R < \eta_I$, i.e. if R were to act as an engine it would give less work output than that of I , i.e. $W < W'$ for a given Q . With R acting as a refrigerator, this would mean $Q_2 = Q_1 - W > Q_1 - W'$. Thus, on a whole, the coupled I - R system extracts heat

$$(Q_1 - W) - (Q_1 - W') = (W' - W)$$

From the cold reservoir it delivers the same amount of work in one cycle, without any change in the source or anywhere else. This is clearly against the Kelvin-Planck statement of the second law of thermodynamics. Hence, the Assertion $\eta_I > \eta_R$ is incorrect.

Thus, no engine can have efficiency greater than that of Carnot engine.

Therefore, Assertion is incorrect but Reason is correct.

- 81 (a)** In an experiment, Benjamin Thomson observed that boring of a brass can non-generated a lot of heat, indeed enough to boil water. More significantly, the amount of heat produced depended on the work done (by horses employed for turning the drill) but not on the sharpness of the drill. The explanation of observation thus could be done by considering that heat is a form of energy and the experiment demonstrated conversion of energy from one form to another (from work to heat).

However, temperature is related to energy of internal (disordered) motion of particles, not to the motion of particles as a whole.

Whether or not a system is in a state of equilibrium depends on the surroundings and the nature of the walls that separates the system from the surroundings.

So, statement I is correct but II and III are incorrect.

- 82 (a)** The statement I is correct but II is incorrect and it can be corrected as,

In SI units, specific heat capacity of water is $4186 \text{ J kg}^{-1} \text{ K}^{-1}$, i.e. $4.186 \text{ J g}^{-1} \text{ K}^{-1}$.

- 83 (a)** A gas allowed to expand freely against vacuum is not an equilibrium state. As during the rapid expansion, pressure of the gas may not be uniform throughout.

Also, thermodynamic state variables describe equilibrium states of the systems. Since, the given system is not in equilibrium state, thus cannot be described by state variables.

So, statement I is correct but II is incorrect.

- 84 (c)** Since U is a state variable, ΔU depends only on the initial & final states and not on the path taken by the gas to go from one state to other.

However, ΔQ and ΔW , in general depend on the path taken to go from the initial to final states.

Thus, from the first law of thermodynamics, i.e.

$$\Delta Q - \Delta W = \Delta U$$

It is clear that the combination $\Delta Q - \Delta W$ is however path independent.

Also, when $\Delta U = 0 \Rightarrow \Delta Q = \Delta W$

Hence, heat supplied to the system is used up entirely by the system in doing work on the environment.

So, statement III is correct but I and II are incorrect.

- 85 (d)** For an isothermal process, temperature is fixed, so the ideal gas equation is given by $pV = \text{constant}$. i.e. pressure of a given mass of gas varies inversely as its volume.

In an isothermal expansion, gas absorbs heat and does work on the environment.

In an isothermal compression, work is done on the gas by the environment and heat is released.

So, all statements are correct.

- 87** (a) Efficiency of a heat engine,

$$\eta = 1 - \frac{Q_2}{Q_1}$$

When $Q_2 = 0$, then $\eta = 1$.

However in practice, $\eta = 1$ is never possible even, if we can eliminate various kinds of losses associated with actual heat engines.

So, statement I is incorrect but II is correct.

- 88** (d) Kelvin and Planck's statements deny the possibility of perfect heat engine and Clausius statement denies the possibility of perfect refrigerator.

Kelvin-Planck statement No process is possible whose sole result is absorption of heat from a reservoir and the complete conversion of the heat into work.

Clausius statement No process is possible whose sole result is the transfer of heat from a colder object to a hotter object.

So, neither statement I nor II is correct.

- 90** (d) All the given processes are irreversible in nature as they cannot be reversed exactly. Otherwise, it would amount to conversion of heat entirely into work, violating the second law of thermodynamics.

So, all statements are correct.

- 91** (d) The statements I, II and III regarding the steps a working substance of a refrigerator goes through are correct. But IV is incorrect and it can be corrected as, Release of heat by the vapour to the surroundings, bringing it to the initial state and completing the cycle.

- 92** (d) Diathermic wall is a conducting wall that allows energy (heat) flow from one to another. Thus, the macroscopic variables of the systems A and B change spontaneously.

and the energy flows between two systems until they both attain equilibrium. Finally, the state variables of two systems become constant.

Thus, the statements given in options (b) and (c) are correct, rest is incorrect.

- 93** (a) As heat and work in thermodynamics are not state variables. They are modes of energy transfer to a system resulting in change in its internal energy. Thus, statement, like a gas in a given state has a certain amount of heat or a gas in a given state has a certain amount of work are meaningless.

In contrast, a gas in a given state has a certain amount of internal energy and a certain amount of heat is supplied to the system or a certain amount of work was done by the system are perfectly meaningful.

Thus, statement given in option (a) is correct, rest are incorrect.

- 94** (c) In order to take the gas from the state (p, T) to (p', T') via a quasi-static process, the external pressure

should be changed by a very small amount, that allow this system to equalise its pressure with surroundings. This process is continued infinitely slowly until the system achieves the pressure p' .

Similarly, temperature can be changed by introducing an infinite-simal temperature difference between the system and surrounding reservoir. Also, by choosing reservoirs of progressively different temperatures T to T' , the system achieves the temperature T' .

Although, quasi-static process is a hypothetical concept, but in practice, the processes that are sufficiently slow and do not involve accelerated motion of the piston, large temperature gradient etc. are reasonably approximation of an ideal quasi-static process.

Also, in such a process at every stage, the system is in equilibrium state.

Thus, the statement given in option (c) is correct, rest are incorrect.

- 95** (b) In an isobaric process, p is fixed, so equation of gas is given as $\frac{V}{T} = \text{constant}$.

Work done by gas, $W = p(V_2 - V_1) = \mu(T_2 - T_1)$.

Since temperature changes, so does internal energy.

Thus, from the first law of thermodynamics, we can say that, heat absorbed goes partly to increase internal energy and partly to do work.

However, for isothermal process, $pV = \text{constant}$.

In a cyclic process, the system returns to its initial state.

Thus, the statement given in option (b) is correct, rest are incorrect.

- 96** (d) The given process is a cyclic process, i.e. it returns to the original state 1.

Hence, change in internal energy, $dU = 0$

From first law of thermodynamics,

$$dQ = dU + dW = 0 + dW = dW$$

Hence, total heat supplied is converted to work done by the gas (mechanical energy) which is not possible by second law of thermodynamics.

When the gas expands adiabatically from 2 to 3. In this case, it is not possible to return to the same state without heat being supplied to the gas, hence the process 3 to 1 cannot be adiabatic.

This implies that curves representing two adiabatic processes do not intersect.

Thus, the statements given in options (a) and (b) are correct, rest is incorrect.

- 97** (b) Change in internal energy for the process A to B ,

$$dU_{A \rightarrow B} = \mu C_V dT = \mu C_V (T_B - T_A)$$

which depends only on temperatures at A and B that are fixed.

It means, internal energy is same for all the cases.

Work done for A to B , $dW_{A \rightarrow B} = \text{Area under the } p-V \text{ curve, which is maximum for the path I.}$

Thus, the statement given in option (b) is correct, rest are incorrect.

98 (c) A quasi-static isothermal expansion of an ideal gas in a cylinder fitted with a frictionless movable piston is a reversible process.

However,

When the rod is hammered, the external work is done on the rod which increases its temperature. The process cannot be retraced itself.

When a gas in a container at a temperature T_1 is brought in contact with T_2 (such that $T_2 > T_1$), then in this process energy, in the form of heat is transferred to the gas in the small container by big reservoir at temperature T_2 . This is also not reversible in nature.

As the weight is added to the cylinder, in the form of external pressure, hence it cannot be reversed back itself.

99 (b)

A. $1 \text{ cal} = 4.186 \text{ J/gK} = \text{heat required to raise temperature of } 1 \text{ g water from } 14.5^\circ \text{C to } 15.5^\circ \text{C}$.

B. $p \left(\frac{\Delta V}{\Delta T} \right)_p = R = \text{universal gas constant}$.

C. Specific heat capacity of solids $= 3R$. (assuming three dimensional oscillator atoms)

D. For isothermal process, $\Delta T = 0$

$$\Rightarrow \Delta U = 0$$

From first law of thermodynamics

$$\Rightarrow \Delta W + \Delta U = \Delta Q$$

$$\Rightarrow \Delta W + 0 = \Delta Q$$

$$\Rightarrow \Delta W = \Delta Q$$

Hence, $A \rightarrow 1, B \rightarrow 2, C \rightarrow 4$ and $D \rightarrow 3$.

101 (b) In isochoric process, the curve is parallel to Y -axis because in it volume is constant.

In isobaric process, the curve is parallel to X -axis because in it pressure is constant.

Thus, process I represents isochoric process, IV represents isobaric process.

Also, $(\text{Slope})_{\text{adiabatic}} > (\text{Slope})_{\text{isothermal}}$

Since, $(\text{Slope})_{\text{III}} < (\text{Slope})_{\text{II}}$

So, process II represents adiabatic process and III represents isothermal process.

Hence, $A \rightarrow 3, B \rightarrow 1, C \rightarrow 4$ and $D \rightarrow 2$.

103 (b) Given, mass of nitrogen, $m = 2.0 \times 10^{-2} \text{ kg}$

Increase in temperature, $\Delta T = 45^\circ \text{C}$

Molecular mass of N_2 ,

$$M = 28 \text{ g} = 28 \times 10^{-3} \text{ kg}$$

$$R = 8.3 \text{ J mol}^{-1} \text{K}^{-1}$$

$$\text{Number of moles, } n = \frac{m}{M} = \frac{2 \times 10^{-2}}{28 \times 10^{-3}} = \frac{5}{7}$$

Molar specific heat at constant pressure,

$$C_p = \frac{7}{2} R$$

\therefore Heat supplied, $Q = n C_p \Delta T$

$$= \frac{5}{7} \times \frac{7}{2} \times 8.3 \times 45 = 933.75 \text{ J}$$

104 (c) Given, $W = 5.4 \times 10^8 \text{ J}$ and $Q = 3.6 \times 10^9 \text{ J}$

$$\text{Efficiency of heat engine, } \eta = \frac{W}{Q} \times 100$$

$$= \frac{5.4 \times 10^8}{3.6 \times 10^9} \times 100 = \frac{3}{20} \times 100 = 15\%$$

Heat wasted per minute $= Q - W$

$$= 3.6 \times 10^9 - 5.4 \times 10^8$$

$$= (36 - 5.4) \times 10^8 \text{ Jmin}^{-1}$$

$$= 30.6 \times 10^8 \text{ Jmin}^{-1} \approx 3.1 \times 10^9 \text{ Jmin}^{-1}$$

105 (d) Heat energy supplied per second by the heater,

$$\Delta Q = 100 \text{ W} = 100 \text{ Js}^{-1}$$

Work done by the system, $\Delta W = +75 \text{ Js}^{-1}$

Rate of change in internal energy, $\Delta U = ?$

According to first law of thermodynamics,

$$\Delta U = \Delta Q - \Delta W = 100 - 75 = 25 \text{ Js}^{-1}$$

106 (b) Coefficient of performance of a refrigerator is given

by $\alpha = \frac{T_2}{T_1 - T_2}$, where T_1 and T_2 are temperatures of source and sink, respectively.

Given, temperature of source,

$$T_1 = (36 + 273) \text{K} = 309 \text{ K}$$

Temperature of sink, $T_2 = (9 + 273) \text{K} = 282 \text{ K}$

Coefficient of performance of a refrigerator,

$$\alpha = \frac{T_2}{T_1 - T_2} = \frac{282}{309 - 282} = \frac{282}{27} = 10.4$$

107 (d) Let initial volume of the gas in the cylinder be V .

$$\therefore V_1 = V \text{ and } V_2 = V/2$$

As no heat transfers with surroundings occur, this means process is adiabatic.

As, $\gamma = 1.4$

For an adiabatic change, $pV^\gamma = \text{constant}$

$$\Rightarrow p_1 V_1^\gamma = p_2 V_2^\gamma$$

$$\therefore \frac{p_2}{p_1} = \left(\frac{V_1}{V_2} \right)^\gamma = \left(\frac{V}{V/2} \right)^{1.4} = (2)^{1.4} = 2.64$$

108 (b) Given, work done, $W = -22.3 \text{ J}$

Work done is taken negative as work is done on the system.

In an adiabatic change, $\Delta Q = 0$

Using first law of thermodynamics,

$$\Delta U = \Delta Q - W = 0 - (-22.3) = 22.3 \text{ J}$$

For another process between states A and B ,

$$\text{Heat absorbed, } \Delta Q = +9.35 \text{ cal} = + (9.35 \times 4.19) \text{ J} \\ = +39.18 \text{ J}$$

Changes in internal energy between two states *via* different paths are equal.

$$\therefore \Delta U = 22.3 \text{ J}$$

So, from first law of thermodynamics,

$$\Delta U = \Delta Q - W \text{ or } W = \Delta Q - \Delta U$$

$$W = 39.18 - 22.3 = 16.88 \text{ J} \approx 16.9 \text{ J}$$

- 109** (c) Work done by a thermodynamic system,
= Area under p - V curve and V -axis; work done is positive, if volume increases and negative, if volume decreases.

$$\begin{aligned} \text{Work done in process } DE &= + \text{Area of } DEHGD \\ &= + (\text{Area of } \triangle DEF + \text{Area of rectangle } EHGF) \\ &= + \left[\frac{1}{2} \times (600 - 300) \times (5 - 2) + 300 \times (5 - 2) \right] \\ &= 450 + 900 = 1350 \text{ J} \end{aligned}$$

$$\begin{aligned} \text{Work done in process, } EF &= - (\text{Area of rectangle } EHGF) \\ &= - [300 \times (5 - 2)] = -900 \text{ J} \end{aligned}$$

$$\begin{aligned} \therefore \text{Total work done by the gas from } D \text{ to } E \text{ to } F, \\ W &= 1350 - 900 = 450 \text{ J} \end{aligned}$$

- 110** (c) For the curve 4, pressure is constant, so this is an isobaric process.

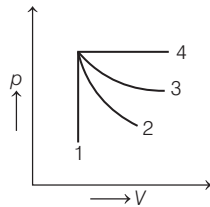

For the curve 1, volume is constant, so it is isochoric process. Between curves 3 and 2, curve 2 is steeper, so it is adiabatic and 3 is isothermal.

- 111** (c) According to the question, the equation of the gas is $pV = \text{constant}$.
Hence, we can say that the gas is going through an isothermal process.

From given graph p - V , it is also seen that the gas is expanding as with increasing volume, the pressure of gas decreasing, i.e. $p_2 < p_1$ at constant temperature. This situation is correctly shown in T - p diagram of option (iii).

- 112** (b) Consider the p - V diagram given in the question.
Work done in the process $ABCD$

$$= \text{Area under the curve } ABCDA$$

$$W_{\text{total}} = W_{AB} + W_{BC} + W_{CD} + W_{DA} \quad \dots(i)$$

$$\text{Here, } W_{BC} = W_{DA} = 0 \quad (\because \Delta V = 0)$$

$$W_{AB} = p_0(3V_0 - V_0) = 2p_0V_0$$

$$W_{CD} = 2p_0(V_0 - 3V_0) = -4p_0V_0$$

Putting the values in Eq. (i), we get

$$W_{\text{total}} = 2p_0V_0 + 0 - 4p_0V_0 + 0 = -2p_0V_0$$

So, work done by the gas is $-2p_0V_0$.

- 113** (a) According to the given question, both the processes involves compression of the gas.

$$\text{For isothermal process (gas A), } p_1V_1 = p_2V_2$$

$$\Rightarrow p_0(2V_0) = p_2(V_0) \Rightarrow p_2 = 2p_0$$

For adiabatic process, (gas B)

$$p_1V_1^\gamma = p_2V_2^\gamma \Rightarrow p_0(2V_0)^\gamma = p_2(V_0)^\gamma$$

$$\Rightarrow p_2 = \left(\frac{2V_0}{V_0} \right)^\gamma p_0 \text{ or } p_2 = (2)^\gamma p_0$$

$$\text{Hence, } \frac{(p_2)_B}{(p_2)_A} = \text{Ratio of final pressures}$$

$$= \frac{(2)^\gamma p_0}{2p_0} = 2^{\gamma-1}$$

where, γ is ratio of specific heat capacities for the gas.

- 114** (d) Given, temperature of the source, $T_1 = 500 \text{ K}$

$$\text{Temperature of the sink, } T_2 = 300 \text{ K}$$

$$\text{Work done per cycle, } W = 1 \text{ kJ} = 1000 \text{ J}$$

$$\text{Heat transferred to the engine per cycle, } Q_1 = ?$$

Efficiency of a Carnot engine,

$$\eta = 1 - \frac{T_2}{T_1} = 1 - \frac{300}{500} = \frac{2}{5}$$

$$\text{Also, } \eta = \frac{W}{Q_1}$$

$$\text{or } Q_1 = \frac{W}{\eta} = \frac{1000}{(2/5)} = 2500 \text{ J}$$

- 115** (b) Given, temperature of source,

$$T_1 = (27 + 273) \text{ K} = 300 \text{ K}$$

$$\text{Temperature of sink, } T_2 = (-3 + 273) \text{ K} = 270 \text{ K}$$

Efficiency of a perfect heat engine is given by

$$\eta = 1 - \frac{T_2}{T_1} = 1 - \frac{270}{300} = \frac{1}{10}$$

Efficiency of refrigerator is 50% of a perfect engine,

$$\eta' = 0.5 \times \eta = \frac{1}{2} \eta = \frac{1}{20}$$

\therefore Coefficient of performance of the refrigerator,

$$\begin{aligned} \alpha &= \frac{Q_2}{W} = \frac{1 - \eta'}{\eta'} \\ &= \frac{1 - (1/20)}{(1/20)} = \frac{19/20}{1/20} = 19 \end{aligned}$$

$$\begin{aligned} \Rightarrow Q_2 &= \alpha W = 19 W \\ &= 19 \times (1 \text{ kW}) = 19 \text{ kW} \end{aligned}$$

Therefore, heat is taken out of the refrigerator at a rate of 19 kJ per second.

- 116** (a) Given, coefficient of performance, $\alpha = 5$

$$T_1 = (27 + 273) \text{ K} = 300 \text{ K}, T_2 = ?$$

$$\begin{aligned} \text{Coefficient of performance, } \alpha &= \frac{T_2}{T_1 - T_2} \\ 5 &= \frac{T_2}{300 - T_2} \end{aligned}$$

$$\Rightarrow 1500 - 5T_2 = T_2$$

$$\Rightarrow 6T_2 = 1500 \Rightarrow T_2 = 250 \text{ K}$$

$$\therefore T_2 = (250 - 273)^\circ \text{C} = -23^\circ \text{C}$$